

KRACHT

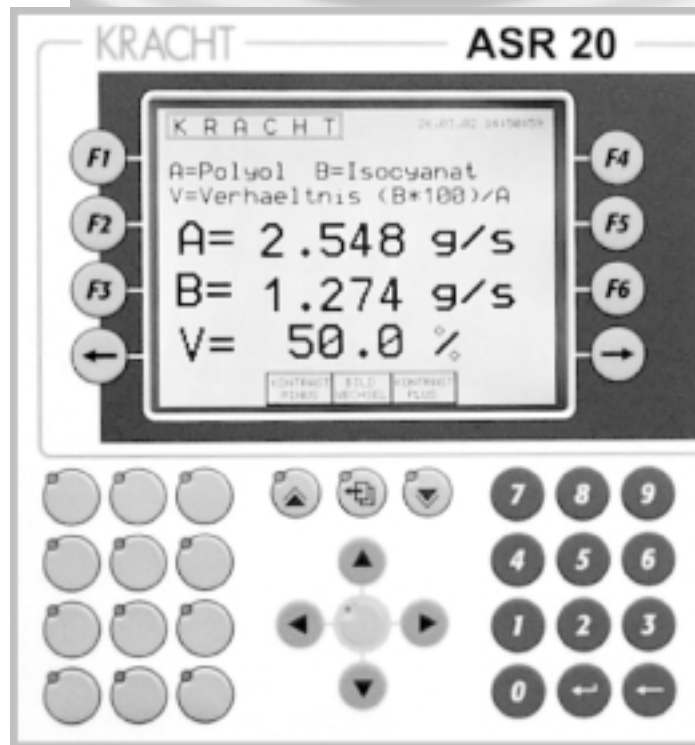

**Electronic**  
**SD 1, AS 8, FM 16, ASR 16, ASR 20**

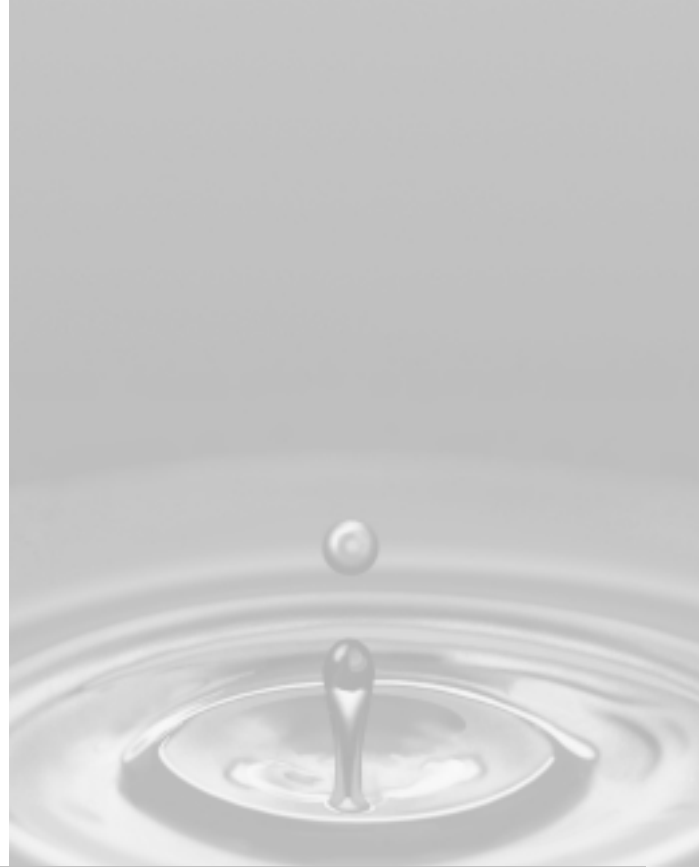

# List of contents

---

Contents	Page
List of contents .....	3
Function ..... SD 1 .....	4
Technical data ..... SD 1 .....	5
Type code, dimensions and electrical connection .... SD 1 .....	6
Function and product characteristics ..... AS 8 .....	7
Technical data ..... AS 8 .....	8
Type code and dimensions ..... AS 8 .....	9
Flow rate / Volumetric measurement ..... AS 8 .....	10
Flow rate controller ..... AS 8 .....	11
Dosing ..... AS 8 .....	12
Cylinder strobe measurement ..... AS 8 .....	13
Flow rate and sum measurement ..... AS 8 .....	14
Flow rate and difference measurement ..... AS 8 .....	15
Ratio measurement ..... AS 8 .....	16
Flow rate and ratio measurement ..... AS 8 .....	17
Ratio controller ..... AS 8 .....	18
AS 8-PUR-TESTER ..... AS 8 .....	19
VC simulator ..... AS 8 .....	20
Function and product characteristics ..... FM 16 .....	21
Technical data ..... FM 16 .....	22
Type code and dimensions ..... FM 16 .....	23
Function and product characteristics ..... ASR 16 .....	24
Technical data ..... ASR 16 .....	25
Type code ..... ASR 16 .....	26
Dimensions ..... ASR 16 .....	27
Function and product characteristics ..... ASR 20 .....	28
Technical data ..... ASR 20 .....	29
Dimensions ..... ASR 20 .....	30

## Plug-in display unit SD 1



### Function

- The plug-in display unit SD 1 may be used with any KRACHT flow meter which uses a plug-in connection according to DIN 43650.
- The display unit is simply inserted between the plug and the plug socket on the volume counter. The displayed value will be the actual flow rate or the volume. The square wave signal remains available for external processing.
- Volume counters already supplied can be equipped with the plug-in display unit. To achieve this the amplifier card must be removed from the plug socket.
- The plug-in display unit is freely programmable. All necessary settings can be achieved with two keys. The programmed data is stored on an FRAM and therefore saved in case of power failure.

### Function + Product characteristics SD 1- Service

- The SD 1 Service is an plug-in display unit which may be used with any KRACHT flowmeter with plug-in connection according to DIN 43650.
- The display unit is simply put on the plug socket of the flow meter.
- The accupack supplies the SD 1 and the sensors with power.
- No separate power supply is necessary.
- If the accu are empty the SD 1 Service can be operated and charged with the enclosed charger.
- The impuls volume is freely programmable.
- All necessary settings can be achieved with two keys.
- The programmed data are stored on a FRAM and therefore saved in case of empty accu.
- With the accu pack an operating time of 30 hours is possible without recharging.

## Technical data SD 1 + SD 1- Service

### SD 1

Processor	PIC 17 C 42
<b>Power unit</b>	
Supply	18 VDC – 28 VDC optional 10 – 19 VDC
Current input	approx. 120 mA
<b>General data</b>	
Display	principle: 7 segment LED, 7.62 mm, red display: 0.000 ... 9999 with floating decimal point overflow (>9999): display 9999
Keyboard	two keys behind the front panel
Housing material	aluminium
Dimensions	height(without plug) approx. 35 mm, width approx. 60 mm, depth approx. 60 mm
Protection (DIN 40050)	IP 65
Weight	approx. 0.12 kg
Connections	angled connector DIN 43650 (4-pins) polarized

<b>Analog output (optional)</b>	current output 0 – 20 mA, 4 – 20 mA load $\leq$ 250 Ohm, at 18–28 VDC supply load $\leq$ 50 Ohm, at 10 VDC supply 10 bit resolution, short-circuit-proof
---------------------------------	---

<b>Pulse output</b>	Incremental signal
Pulse amplitude	approx. 0.8 x supply voltage
Pulse shape with symmetrical output signal	square wave, pulse duty factor/channel 1:1, +/- 15 %
Pulse offset between two channels	90°, +/- 30°
Output power/channel	$P_{a\max}$ = max. 0.3 W short-circuit-proof

### Environmental conditions

Operating temperature	0 °C up to +60 °C
Storage temperature	-25 °C up to +85 °C

### SD 1- Service

Processor	PIC 17 C 42
<b>Current supply</b>	
Accumulator	6 VDC
Working time	approx. 30 hours
<b>Battery charger</b>	
Input voltage	230 VAC
Charging current	max. 700 mA
Charging time	approx. 4 hours

### General characteristics

Display	principle: 7 segment LED, 7.62 mm, red display: 0.000 ... 9999 with floating point overflow (>9999): display 9999
Keyboard	two keys on the front side
Housing material	aluminium
Protection (DIN 40050)	IP 65
Weight	approx. 0.46 kg
Connections	angled connector DIN 43650 (4-pins) polarized

### Environmental conditions

Operating temperature	0 °C up to +60 °C
Storage temperature	-10 °C up to +85 °C

# Type code, dimensions and electrical connections SD 1

## Type code

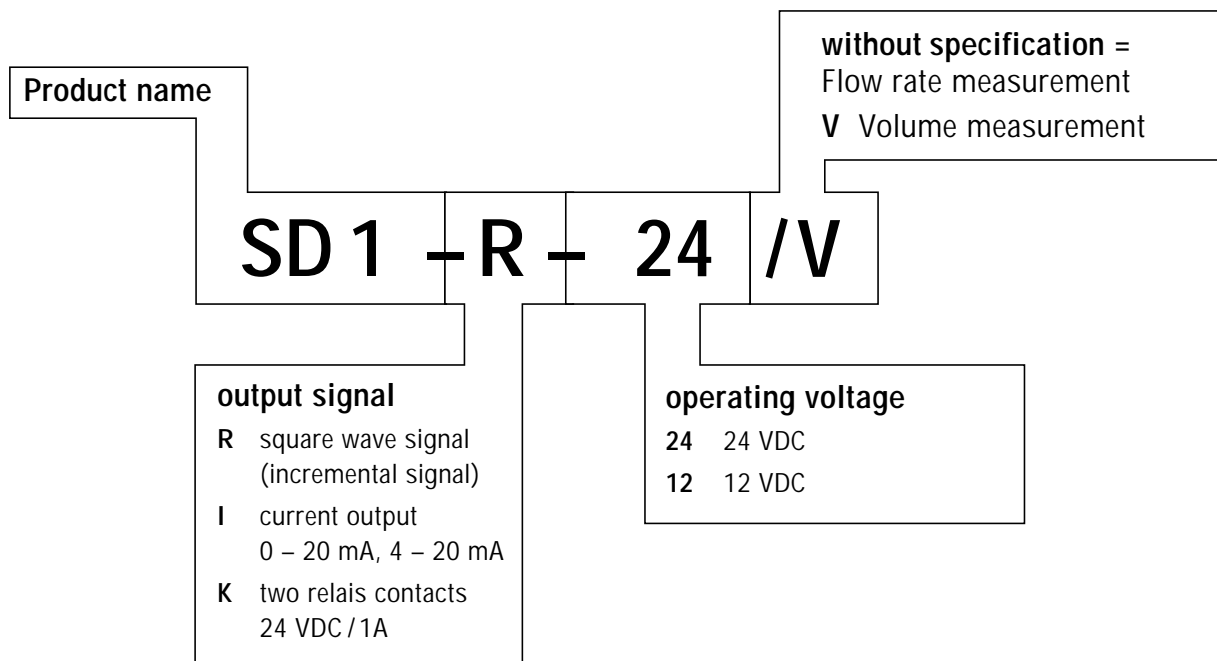

## Dimensions

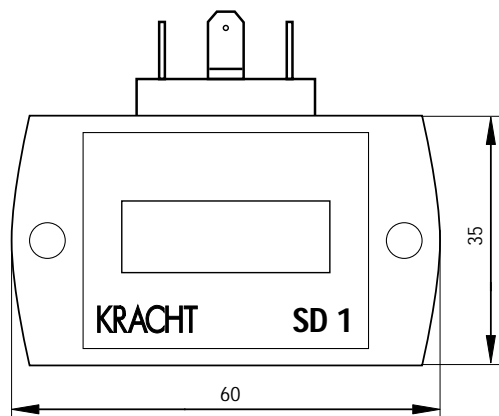

## Electrical connection

### Version: K

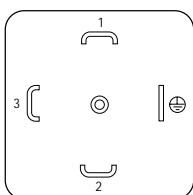

PIN 1 = 12/24 VDC  
 PIN 2 = GND  
 PIN 3 = Relais 1  
 PIN ⊕ = Relais 2

### Version: I

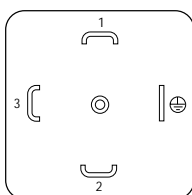

PIN 1 = 12/24 VDC  
 PIN 2 = GND  
 PIN 3 = 0/4-20 mA  
 PIN ⊕ = —

### Version: R

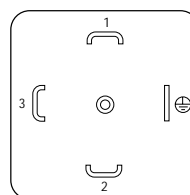

PIN 1 = 12/24 VDC  
 PIN 2 = GND  
 PIN 3 = Channel 1  
 PIN ⊕ = Channel 2

At version V = Volume measurement on Pin ⊕ lays „Enable Summation“

# Function and product characteristics AS 8



## Function

- The microcontroller AS 8 processes incremental input signals from KRACHT Volume Counters and other sensors.
- The input signals are filtered in the unit, interpreted and converted into the values of flow rate and volume.
- The user may choose to have either flow rate or volume displayed.
- Two relays, one analog output or one serial interface are available for further, external processing.

## Product characteristics

- EMC construction
- programmable micro-processor
- used for KRACHT Volume Counters and other sensors with 24 volt incremental signals
- power supply voltage 230 /120 V 50/60 Hz 24 VDC / 12 VDC
- integrated sensor power supply 24 VDC 50 mA
- flow rate or volume measurement
- smoothing function by means of a digital filter
- 2 programmable relays
- user-selected analog output
  - current:  $\pm 20$  mA, 0...20 mA, 4...20 mA
  - voltage:  $\pm 10$  V, 0...10 V,
- serial interface RS 232
- selectable time basis (sec, min, hrs)
- selectable units for display
- enclosure with dimensions according to DIN

## Examples of application

- flow rate measurement . . . . .hydraulic test stand
- volume measurement . . . . .consumption record
- volume measurement . . . . .indirect cylinder
- . . . . .path measurement
- ratio measurement . . . . .two-component devices
- dosing . . . . .filling units
- test apparatus . . . . .volume counter

# Technical data AS 8

## Processor

## PIC 17C42

Supply	230 VAC, + 6% ... - 10% / 50 - 60 Hz, optional 120 VAC, 24 VDC, 12 VDC
Power input (power consumption)	ca. 3.5 W
Sensor supply	24 VDC +/- 20%, 50 mA

### General data

Display	principle: 7 segment LED, 13.2 mm, red display: 0.000 ... 9999 with floating decimal point overflow (>9999): display 9999 overflow (<-9999): display -9999 status indicator: LEDs K1 and K2 for relays 1 and 2
Keyboard	three keys behind the front panel, optional keys on front panel
Housing	for switch panel plug-in unit made of plastic
Panel frame	96 x 48 mm, DIN 43700
Insertion depth	ca. 122 mm with plug board
Panel cutout	92 x 45 mm, tolerance +0.8 x +0.6 mm
Protection (DIN 40050)	IP 54 in appropriate switch panel mounting
Ground (weight)	approx. 0.4 kg
Connections	15 pins terminal connecting block

<b>2 relay contacts</b>	one normally-open-contact switching-time each
-------------------------	---

### 2 digital inputs

Input impedance	>= 7500 Ohm
Input amplitude	low <= 9 volt, high >= 12 volt
Switching time	typ. 1 ms

### 1 analogue output

Voltage output or Current output	current or voltage output adjustable by means of jumper ± 10 volt, 0 - 10 volt, 2 - 10 volt / load >= 1 kOhm, 10 bit resolution, short-circuit-proof ± 20 mA, 0 - 20 mA, 4 - 20 mA / load <= 250 Ohm, 10 bit resolution, short-circuit-proof
--	--

### 1 volume counter input

Input impedance	>= 7500 Ohm
Input amplitude	low <= 9 volt, high >= 12 volt
Rate-of-flow principle of measurement	period length measurement (rising tooth flank)
Maximum input frequency	1Hz ... 2500 Hz
Measurement range totalizer	2 x 10 <sup>9</sup> pulses

### Serial interface

<u>RS 232</u>	cable length <= 15 m
Input voltage	max. ± 30 V
Input current	typ. ± 3 mA at ± 9 V input voltage
Output current	typ. ± 3 mA
Adjustment (selection)	9600 baud, 8 bit, no parity, 1 stop bit
Cable	shield data cables recommended

### Environmental conditions

Operating temperature	0 °C up to +60 °C
Storage temperature	-25 °C up to +85 °C

# Type code and dimensions AS 8

## Type code

**EXAMPLE** **AS 8 – U – 230 – ... / F**

**Product name**

**Analogue output**

**U** Voltage ± 10 V

**I** Current ± 20 mA

**RS** Serial interface RS 232

**O** without analog output (RS 232 available) just for 12 and 24 volt

**Power supply voltage**

**230** 230 V – 50/60 Hz

**120** 120 V – 50/60 Hz

**24** 24 VDC

**12** 12 VDC

**Keyboard**

**without specification** = Switches behind front cover

**F** with keys on front panel

**Versions**

**without specification**  
Standard = Flow rate or volumetric measurement

**RP** Flow rate controller

**DOS** Dosing program

**ZM** Cylinder stroke measurement

**A2F** Flow rate and sum measurement

**D2F** Flow rate and difference measurement

**VA** Ratio measurement

**V2F** Flow rate and ratio measurement

**PUR** Ratio controller

**FM20** Flow rate indication switchable for all KRACHT volume counter

**SIM** Simulator for volumetric meter

**Optional:** Desktop unit  
19" plug-in unit

## Dimensions

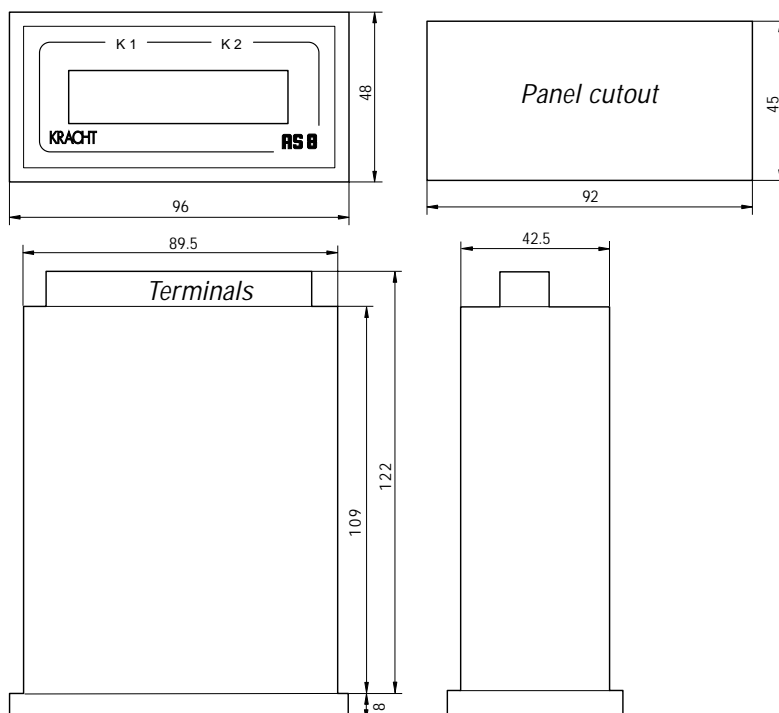

# Flow rate / Volumetric measurement AS 8 - standard

## Flow rate measurement

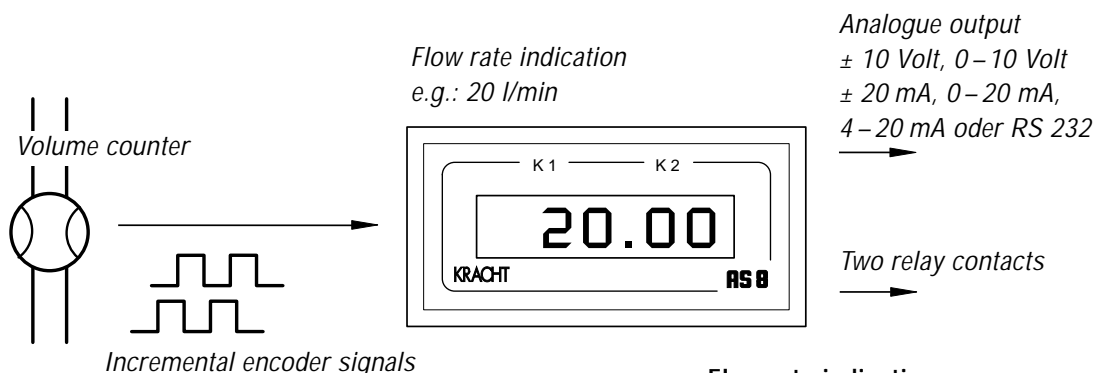

### Flow rate indication

- The incremental input signals are filtered, converted and processed by the microcontroller to yield the dimensions of flow rate.
- Any of the following physical units can be set for the indicator reading: l/h, l/min, l/s, or US gal/hr, US gal/min, US gal/s.

## Volumetric measurement

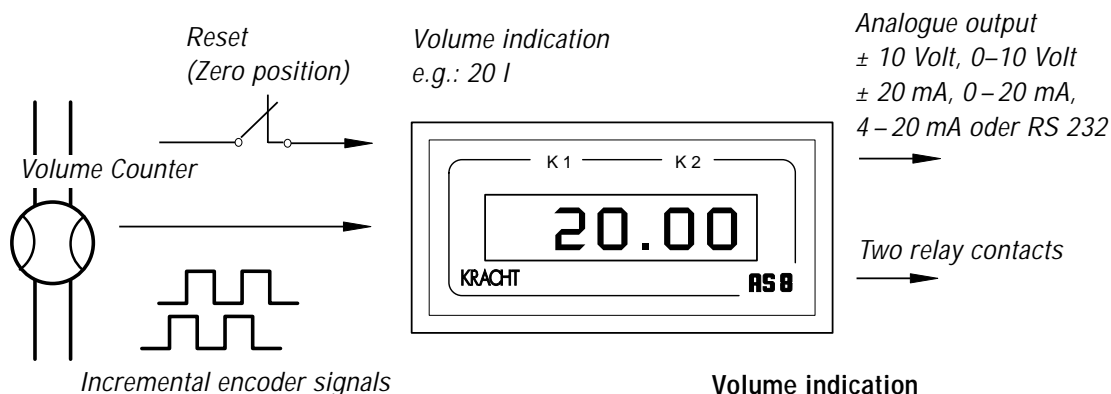

### Volume indication

- The incremental input signals are summed and converted to the dimensions of volume by the microcontroller, using a programmable factor.
- The physical units l and US gal can be set for display.
- A 24 volt digital input enables the summation to be reset to zero.

## Functional characteristics

- The standard version AS 8 is an indication and control device for dynamic flow rate and volume measurement. The setting is made by means of three keys, which are accessible on removal of the front cover.
- Optional via keys on front panel (version /F).
- The switch-over between the display units is made by means of DIP switches, located behind the front cover.
- Two programmable relays, an analogue output, or an RS 232 serial interface, are available for further external processing.
- The integrated 24 VDC transducer supply enables the Volume Counter to be directly connected.
- The type AS 8 series measuring devices are available as built-in control panel units, as bench units or as 19" rack-mounted units.

# Flow rate controller AS 8-RP

## Flow rate controller

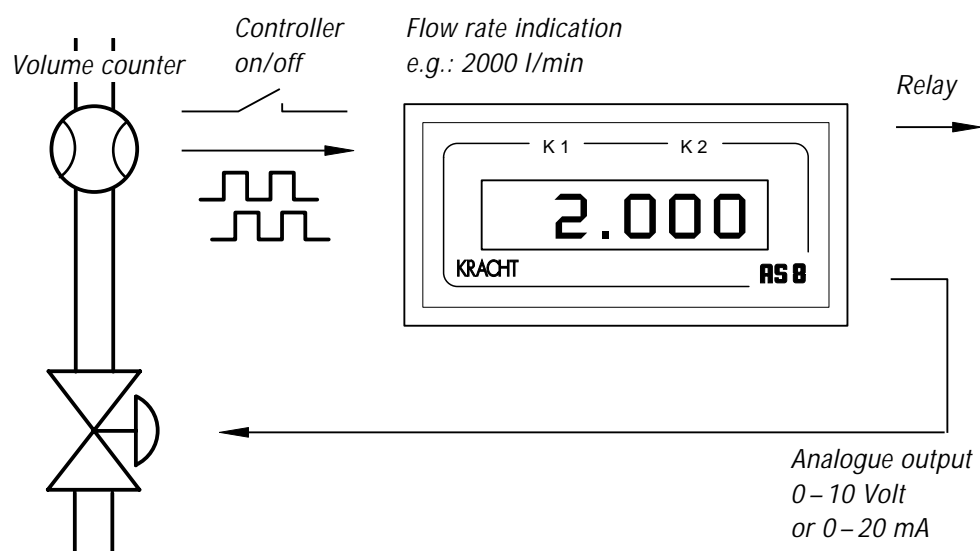

### Flow rate controller

- The AS 8-RP Flow rate controller version controls the flow rate of a component.
- The required flow rate is set on the AS 8. The flow rate is detected by the Volume Counter and fed to the AS 8 as a square-wave signal.
- The controller output is connected to a continuously variable valve via a position amplifier, or is used to control the speed of a delivery pump.

## Rotational speed controller

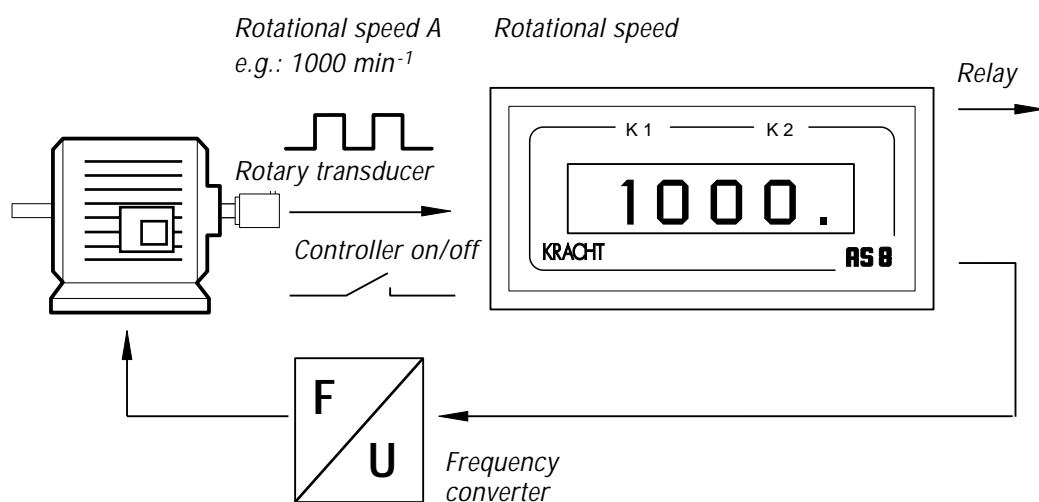

### Rotational speed controller

- A further application example is that of rotational speed regulation.
- The required speed is set on the AS 8. The actual rotational speed is detected by the rotary transducer and fed to the AS 8 as a square-wave signal.
- The controller output is connected to the motor via a frequency converter and used to control the rotational speed.

## Functional characteristics

- Two relay contacts enable the overshoot of permissible error bandwidths to be signalled.
- Programming and setting is carried out by means of three keys which are accessible on removal of the front cover. Optional via keys on front panel (version /F).
- The integrated 24 VDC transducer supply enables the direct connection of the Volume Counter.
- The type AS 8 series measuring devices are available as built-in control panel units, as bench units, or as 19" rack-mounted units.

## Dosing AS 8-DOS

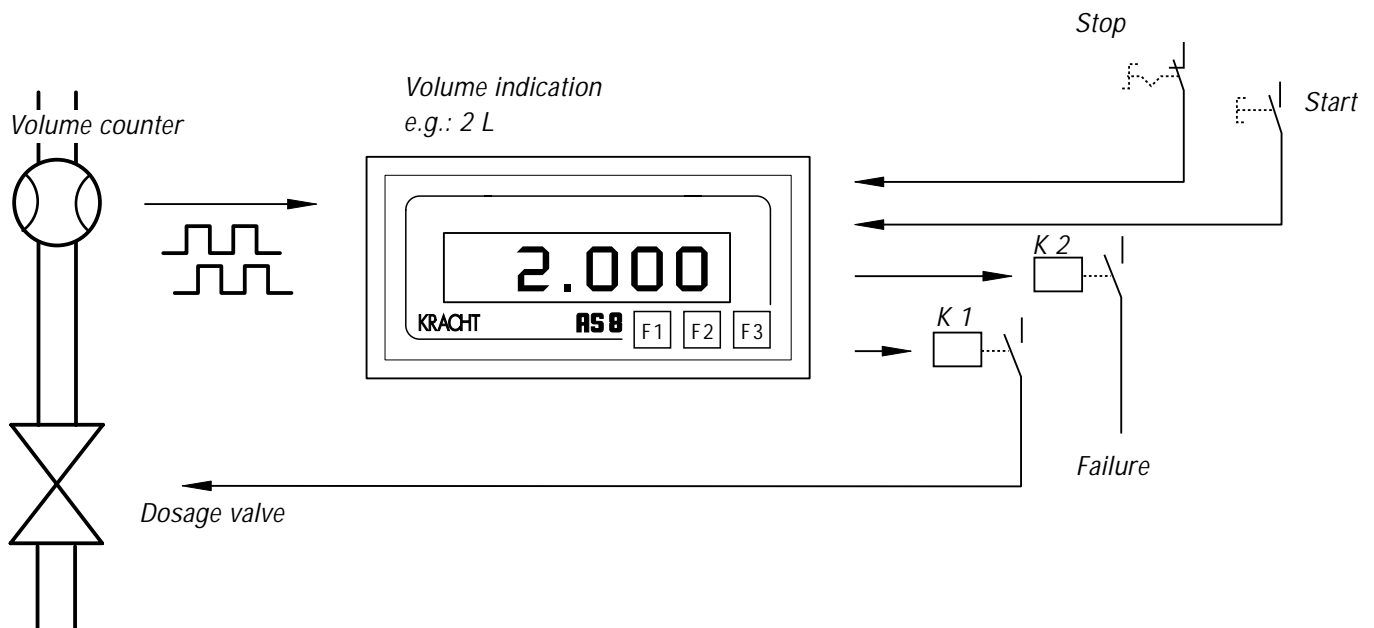

### Functional characteristics

- The AS 8 dosing version is especially designed for employment in dosing lines. It allows of one Volume Counter to be connected.
- 6 dosages (programmes) can be stored in the AS 8. Specific dosages are called up via the three keys on the front panel. The input values are arranged in menus.
- The filling process is started by the digital input. The AS 8 resets the last dosage quantity and switches the dosage valve. The Volume Counter measures the flow and delivers square wave signals to the AS 8. The AS 8 sums the input signals. When the quantity is reached the dosage valve will be switched.
- The second relays contact enables the indication of faulty dosages.
- The settings are made by using the three keys on the front panel. The input values are arranged in menus.
- The integrated 24 VDC sensor supply enables direct connection to the Volume Counter.
- The type AS 8 measuring devices are available as built-in control panel units, as desk-top units, or as 19" rack-mounted units.

# Cylinder stroke measurement AS 8 - ZM

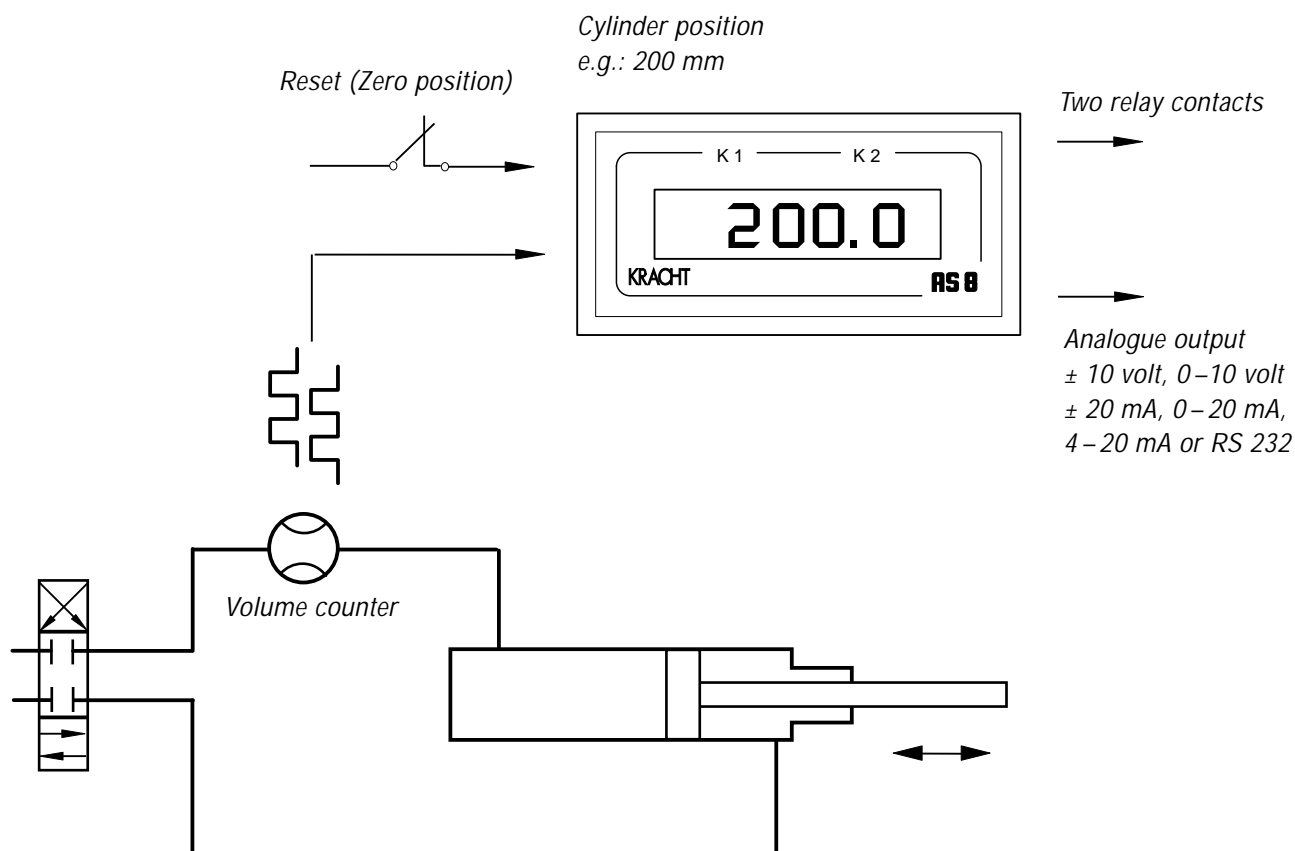

## Functional characteristics

- The cylinder stroke measurement version of the AS 8 enables an indirect measurement to be made of hydraulic drive movements, in combination with a Volume Counter.
- In this system, the Volume Counter is installed in an operating line, to generate pulses which are proportional to the flow rate and to indicate the direction of flow.
- The electrical pulses are converted by the micro-controller into the physical dimensions of flow rate and volume, or stroke and velocity.
- Erroneous measurements, due to leakage at the end positions, can be prevented by means of a programmable blocking frequency. The signals are only processed when the flow rate exceeds the blocking frequency.
- Two relays, an analogue output or an RS 232 interface, are available for additional external processing.
- Programming and setting is carried out by means of three keys, which are accessible on removal of the front cover.
- The integrated 24 VDC transducer supply enables the direct connection of the Volume Counter.
- The type AS 8 series measuring devices are available as built-in control panel units, as bench units, or as 19" rack-mounted units.

# Flow rate and sum measurement AS 8 - A2F

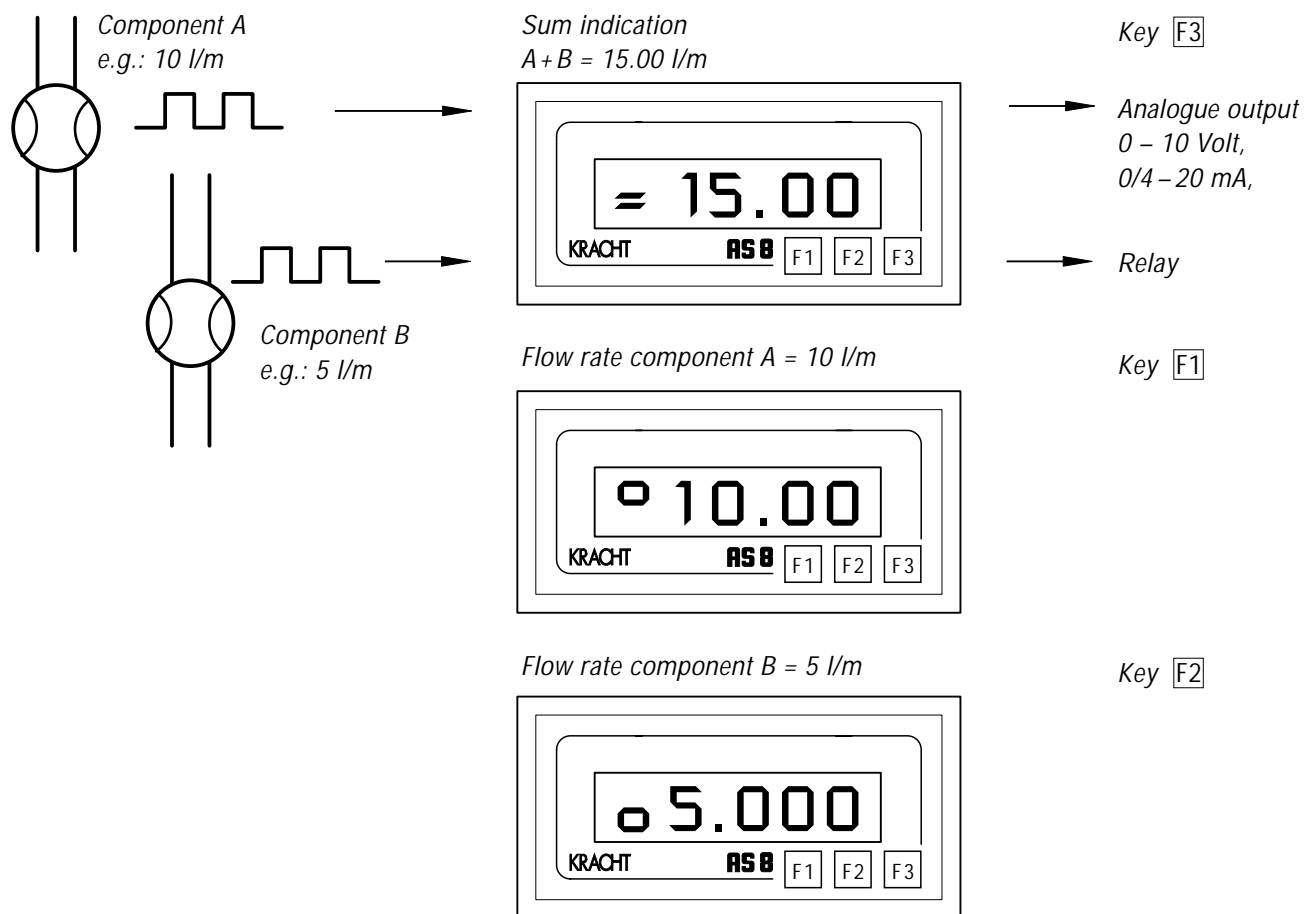

## Functional characteristics

- Two Volume Counters could be connected to the AS 8-A2F. The AS 8 shows the flow rate of component A and B and the sum A+B.
- The different indications are switched by the keys **F1**, **F2** and **F3**.
- For each Volume Counter a density factor can be put in.
- One square-wave signal is required of each Volume Counter. The input signals are filtered, converted and processed by the micro-controller to yield a sum.
- The settings are made using the three keys of the Front panel. The input values are arranged in menus.
- Two relay contacts, an analogue output or an RS 232 interface are available for additional external processing.
- The integrated 24 VDC transducer supply enables the direct connection of the Volume Counter.
- The type AS 8 series measuring devices are available as built-in control panel units, as bench units, or as 19" rackmounted units.

## Flow rate and difference measurement AS 8 - D2F

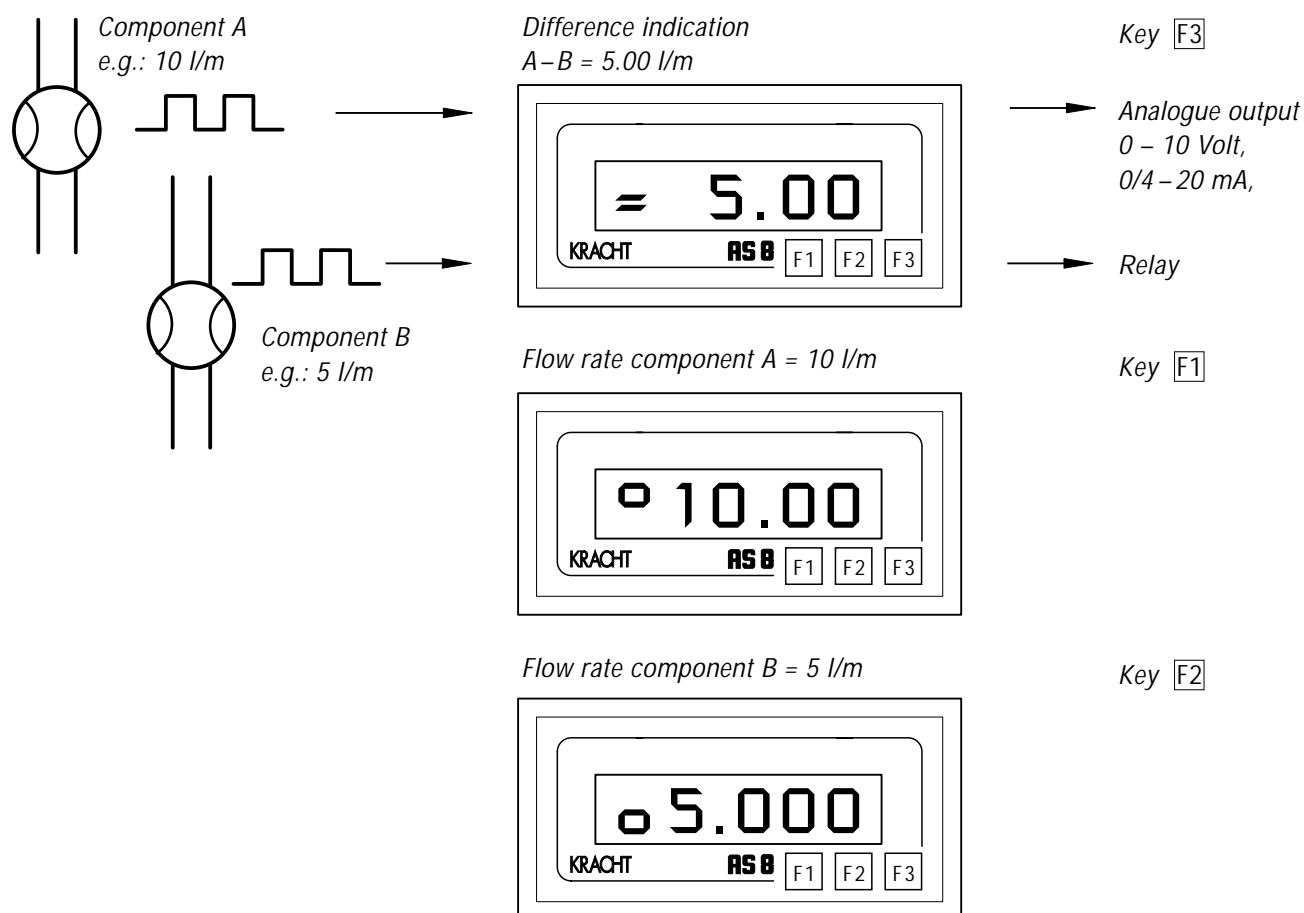

### Functional characteristics

- Two Volume Counters could be connected to the AS 8-D2F. The AS 8 shows the flow rate of component A and B and the difference A-B.
- The different indications are switched by the keys **F1**, **F2** and **F3**.
- For each Volume Counter a density factor can be put in.
- One square-wave signal is required of each Volume Counter. The input signals are filtered, converted and processed by the microcontroller to yield a difference.
- The settings are made using the three keys of the front panel. The input values are arranged in menus.
- Two relay contacts, an analogue output or an RS 232 interface are available for additional external processing.
- The integrated 24 VDC transducer supply enables the direct connection of the Volume Counter.
- The type AS 8 series measuring devices are available as built-in control panel units, as bench units, or as 19" rackmounted units.

# Ratio measurement AS 8-VA

## Mixture ratio measurement

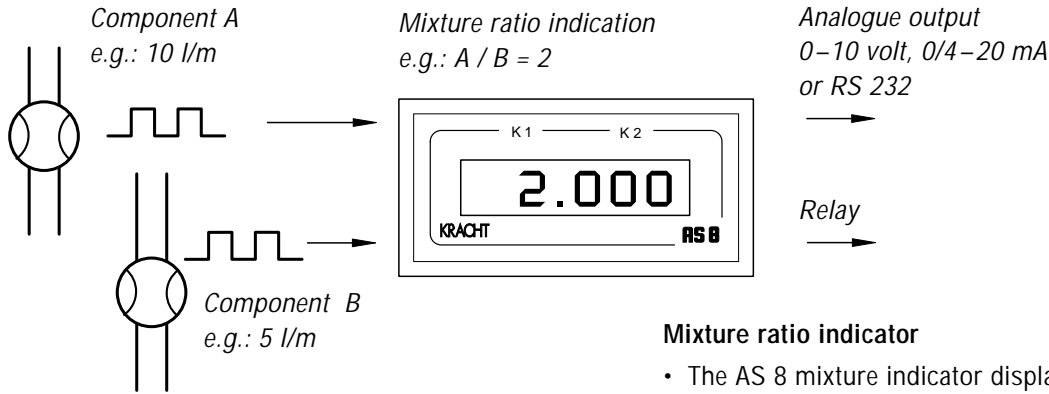

### Mixture ratio indicator

- The AS 8 mixture indicator displays the mixing ratio of two components.
- A square-wave signal is required from each volumetric meter. The input signals are filtered, converted and processed by the micro-controller to yield a mixture ratio.

## Rotational speed ratio measurement

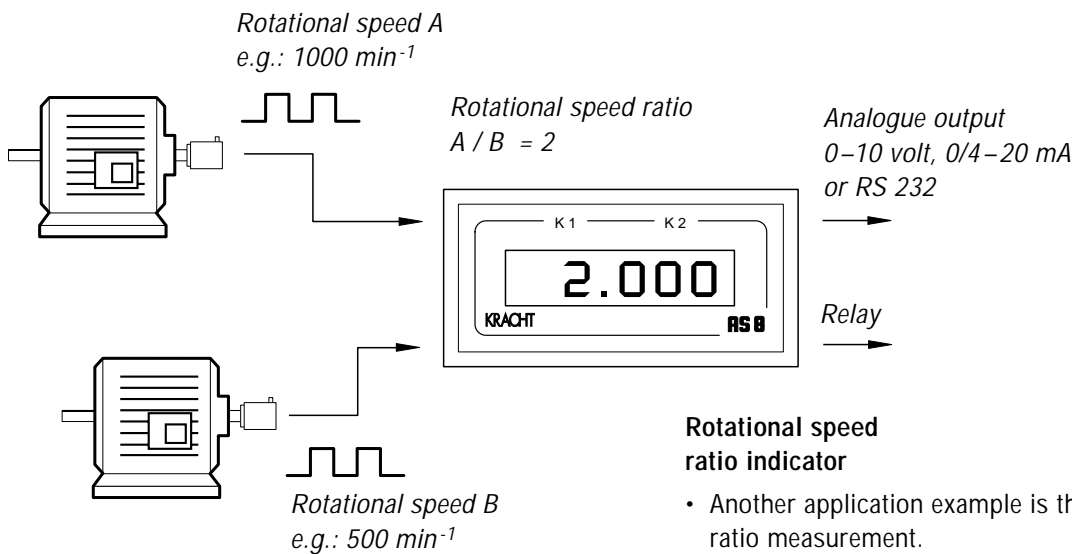

### Rotational speed ratio indicator

- Another application example is that of rotational speed ratio measurement. The pulse trains A and B from the rotary transducers are detected and indicated on the AS 8 as a rotational speed ratio.

## Functional characteristics

- Two programmable relays, an analogue output, or an RS 232 serial interface, are available for further external processing.
- The programming and settings are achieved via three keys, accessible on removal of the front cover. Optional via keys on front panel (version /F).
- The integrated 24 VDC transducer supply enables the direct connection of the Volume Counter.
- The type AS 8 series measuring devices are available as built-in control panel units, as bench units, or as 19" rack-mounted units.

## Flow rate and Ratio measurement AS 8 - V2F

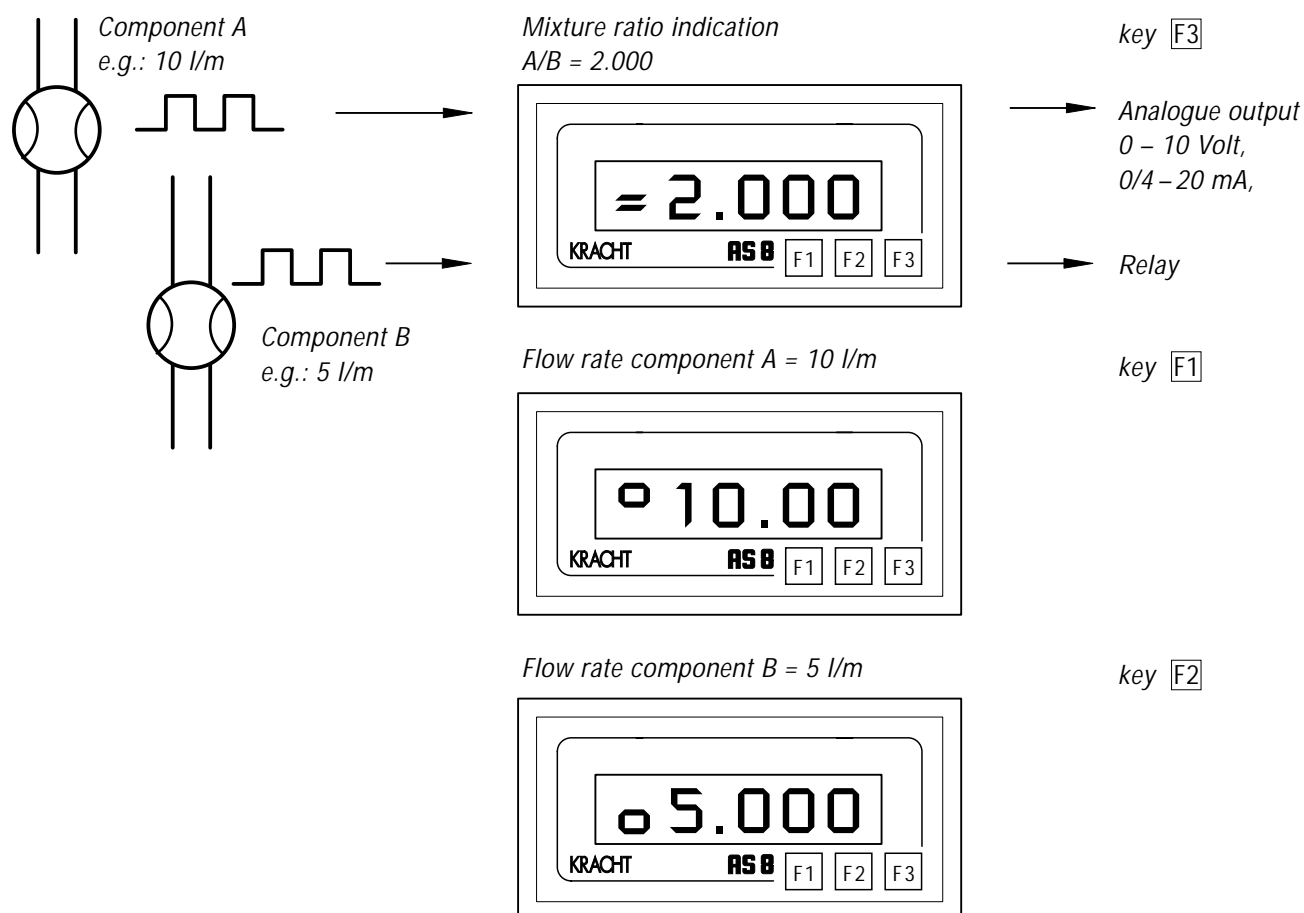

### Functional characteristics

- Two Volume Counters could be connected to the AS 8-V2F. The AS 8 shows the flow rate of component A and B and the mixture ratio A/B.
- The different indications are switched by the keys **F1**, **F2** and **F3**.
- For each Volume Counter a density factor can be put in.
- One square-wave signal is required of each Volume Counter. The input signals are filtered, converted and processed by the micro-controller to yield a mixture ratio.
- The settings are made using the three keys of the front panel. The input values are arranged in menus.
- Two relay contacts, an analogue output or an RS 232 interface are available for additional external processing.
- The integrated 24 VDC transducer supply enables the direct connection of the Volume Counter.
- The type AS 8 series measuring devices are available as built-in control panel units, as bench units, or as 19" rackmounted units.

# Ratio controller AS 8 - PUR

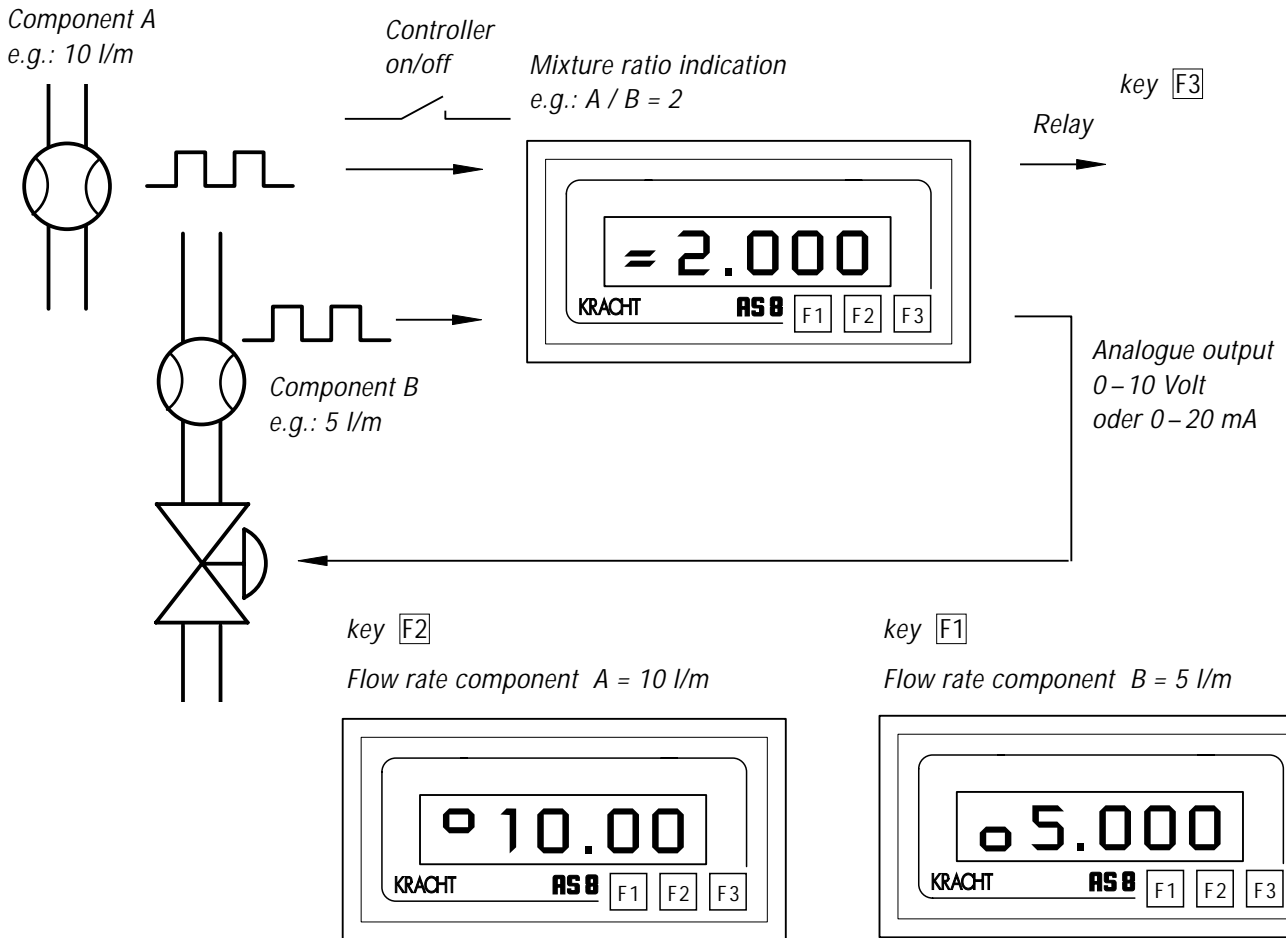

## Functional characteristics

- The ratio controller version of the AS 8 controls the mixing ratio of two components.
- The mixing ratio of the reference component A to component B is set on the AS 8.
- The volumetric flows are detected by the Volume Counter and fed to the AS 8 as square-wave signals. The input signals are filtered, converted and processed by the micro-controller, to yield a mixing ratio. The controller output is either directly connected, or connected via a position amplifier, to a continuously controllable valve, or used to control the speed of a delivery pump.
- Two relay contacts enable the overshoot of permissible error bandwidths to be signalled.
- All settings are made using three keys, which are accessible on removal of the front cover. Optional via keys on front panel (version /F). The input values are arranged in menus.
- The integrated 24 VDC transducer supply enables the direct connection of the Volume Counter.

# AS 8 PUR-TESTER

Front view

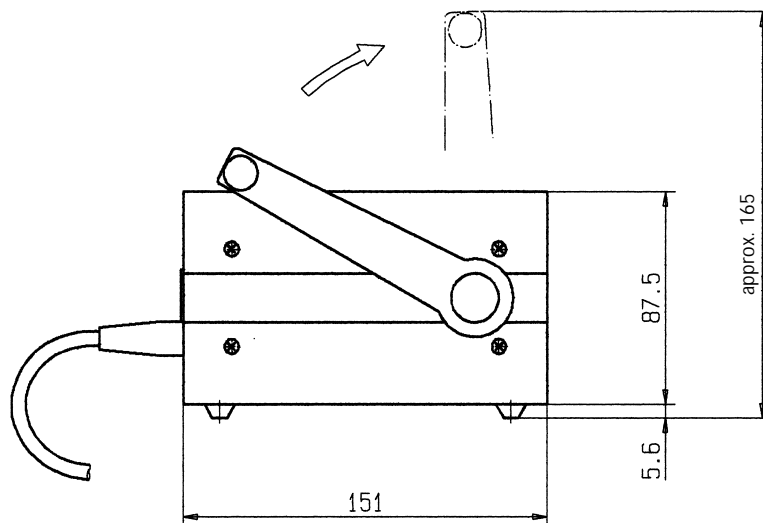
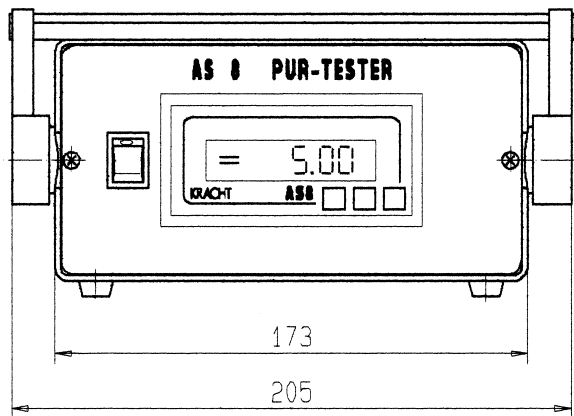

Rear view with analogue output

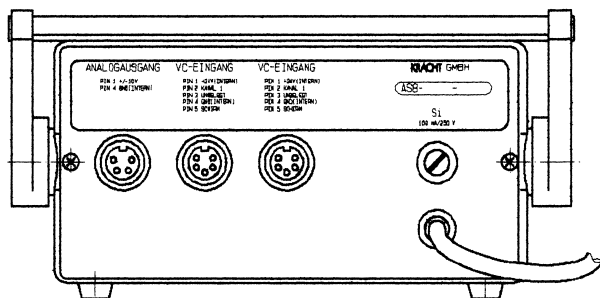

All dimensions in mm

**The delivery contains:**

- AS 8 with keys on front panel, software version V2F assembled in a desk-top unit.
- 2 cables for Cannon-connector.
- 2 cables for Hirschmann-connector.

## Functional characteristics

- The volume counters could be connected to the AS 8 PUR-TESTER. Depending on the volume counters type of connection either the cables with Cannon-connector or with Hirschmann-connector have to be used.
- The AS 8 PUR-TESTER shows the flow rate of component A and B and the mixture ratio A/B.
- The different indications are switched by the keys **F1**, **F2** and **F3**. For each volume counter a density factor can be put in.
- One square-wave signal is required of each volume counter. This input signals are filtered, converted and processed by the micro-controller to yield a mixture ratio.
- The setting are made using the three keys on the front panel. The input values are arranged in menus.
- An analogue output is available for additional external processing. The integrated 24 VDC transducer supplies enables the direct connection of the volume counter.

# Flow rate display unit AS 8 - FM20

Front view

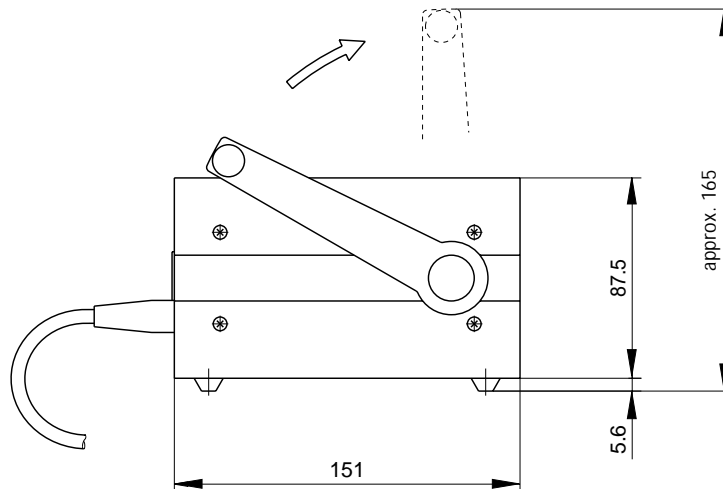
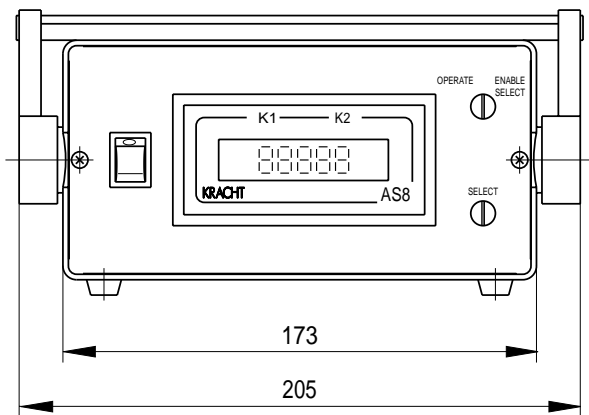

Rear view with analogue output

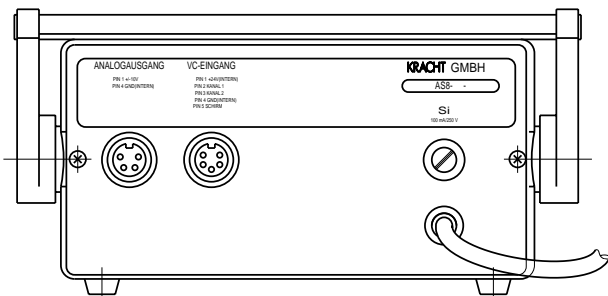

All dimensions in mm

## Functional characteristics

- One Volume counter can be connected to the AS 8-FM20.
- By pressing the „Select“ – button each Volume Counter size of KRACHT GmbH can be selected. The internal configuration like geometrical tooth volume and the setting of the analogue output are made automatically.
- The indication is made in l/min. The selection of current or voltage analogue output can be made by changing the jumper position inside the AS 8.
- The AS 8-FM20 will be delivered in a desk-top unit.

## Function and product characteristics FM 16



### Function

- The microcontroller FM 16 processes incremental input signals from KRACHT Volume Counters and other sensors.
- The input signals are interpreted in the processor using a measuring technique similar to that of the period length measurement, whereby the acceleration (or deceleration) of the volume flow influences the determination of the current flow rate. This measurement process makes the current flow rate available as an analog value at any time. The result is a very precise measurement, even with highly dynamic processes. (e.g. zero crossing during volumetric reversal)

### Product characteristics

- EMC construction
- programmable micro-processor
- used for KRACHT Volume Counters and other sensors with 24 volt incremental signals
- power supply voltage 24 VDC
- flow rate measurement
- leveling function by means of a digital filter
- user-selected analog output  
current:  $\pm 20$  mA  
voltage:  $\pm 10$  V
- serial interface RS 232
- illuminated display
- three short-stroke keys with film covering
- enclosure with dimensions according to DIN.

### Example of application

preparing of valve characteristic curves . . . test stand

## Technical data FM 16

### Processor **SAB 80C 166 CPU**

#### Power unit

Supply	24 VDC
Power input (power consumption)	approx. 4.5 W

#### General data

Display	two-line LC display with 16 characters each, character height 8 mm, illuminated background RED
Keyboard	three mechanical short-stroke keys, stroke distance 0.5 mm
Housing	housing for switch panel plug-in unit made of plastic
Panel frame	144 x 72 mm, DIN 43700
Insertion depth	ca. 170 mm with plug board
Panel cutout	138 x 68 mm, tolerance +1.0 x +0.7 mm
Protection (DIN 40050)	IP 54 in appropriate switch panel mounting
Ground (weight)	approx. 1 kg

<b>4 relay contacts</b>	one normally-open-contact switching-time each
-------------------------	---

<b>4 digital inputs</b>	electrical isolated by the optocoupler
Input impedance	$\geq 6 \text{ k}\Omega$
Input amplitude	low $\leq 10 \text{ volt}$ , high $\geq 12 \text{ volt}$
Switching time	typ. 1 ms

<b>4 analogue inputs</b>	galvanical isolated for 24 volt supply
Input impedance	unit on: $> 20 \text{ k}\Omega$ unit off: $> 10 \text{ k}\Omega$
Signal selection	0 – 10 volt, 10 bit resolution
Protection wiring	Protective circuit against excessive voltage, max. input voltage 30 volts

<b>1 analogue output</b>	current or voltage output adjustable by means of jumper
Voltage output	$\pm 10 \text{ volt}$ , 0 – 10 volt, 2 – 10 volt / load $\geq 1 \text{ k}\Omega$ , 12 bit resolution, short-circuit-proof
Current output	$\pm 20 \text{ mA}$ , 0 – 20 mA, 4 – 20 mA / load $\leq 250 \text{ }\Omega$ , 12 bit resolution, short-circuit-proof

<b>1 volume counter input</b>	electrical isolated by the optocoupler
Input impedance	6 k $\Omega$
Input amplitude	low $\leq 11 \text{ volt}$ , high $\geq 13 \text{ volt}$
Rate-of-flow principle of measurement	period length measurement taking into consideration the acceleration of the gear pair
Maximum input frequency	$< 10 \text{ kHz}$

#### Serial interfaces

<b>RS 232</b>	cable length $\leq 15 \text{ m}$
Input voltage	max. $\pm 30 \text{ V}$
Input current	typ. $\pm 3 \text{ mA}$ at $\pm 9 \text{ V}$ input voltage
Output current	typ. $\pm 3 \text{ mA}$
Adjustment (selection)	9600 baud, 8 bit, no parity, 1 stop bit
Cable	shield data cables recommended
<b>RS 485</b>	electrical isolated by the optocoupler
Input impedance	$\geq 12 \text{ k}\Omega$
Adjustment (selection)	75, 600, 1200, 2400, 4800, 9600, 19200, 38400 baud 7 or 8 bit data width, selectable parity, 1 or 2 stop bits
Cable	shielded data cables, twisted pairs, recommended

#### Environmental conditions

Operating temperature	0 °C up to +50 °C
Storage temperature	-25 °C up to +85 °C

# Type code and dimensions FM 16

## Type code

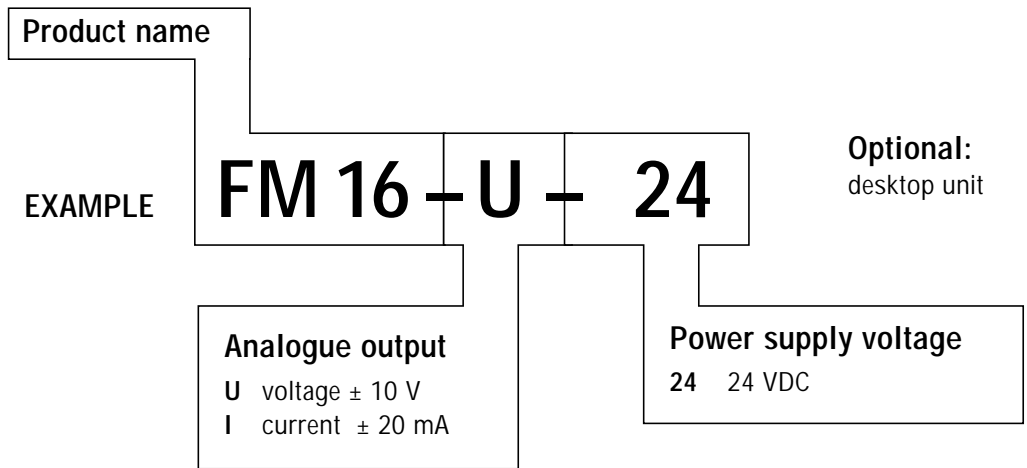

## Dimensions

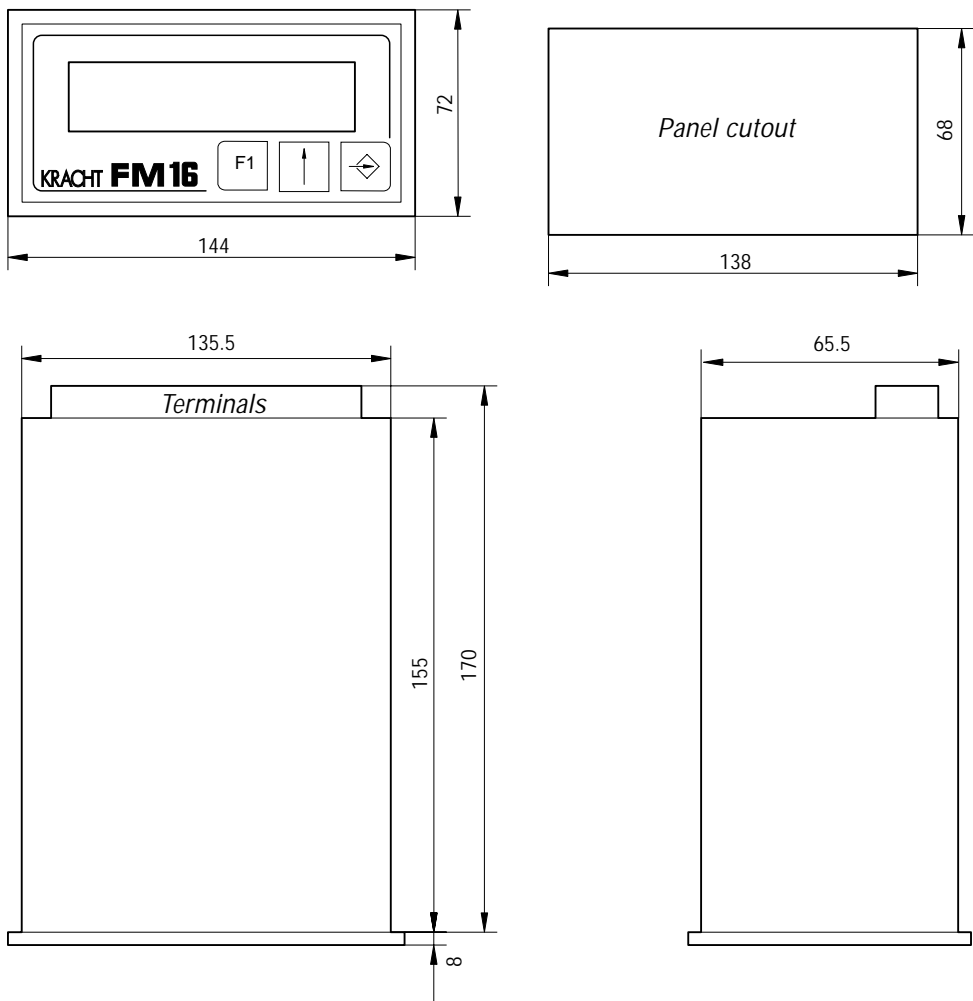

## Function and product characteristics ASR 16



### Function

- The microcontroller ASR 16 processes incremental input signals.
- The input signals are filtered in the unit, interpreted and converted into the physical sizes flow rate and volume.
- Analogue inputs allow the connection of pressure transducers, temperature sensors and the like.
- All measurements from the electronic sensors are indicated on the display.
- Relay contacts, analogue outputs and serial interfaces are available for further, external processing.
- Standardized programs are available for a wide variety of applications.
- Data input – by means of the keyboard – is menu-driven; the dialogue language is either German or English.

### Product characteristics

- EMC construction
- programmable microprocessor
- Used for KRACHT Volume Counters and other sensors with 24 volt incremental signals
- power supply voltage 24 VDC
- Easily surveyed LC display
- Functions for set parameters and configuration are password protected.
- Serial interface for printer or configuration serial (in series)
- standardized programs allow for a variety of applications
- leveling function by means of a digital filter
- data storage in battery-buffered RAM
- bilingual operation: German/English
- up to four analogue control outputs.  
current:  $\pm 20$  mA,  
0–20 mA, 4–20 mA or  
voltage:  $\pm 10$  volt,  
0–10 volt
- up to sixteen binary inputs / outputs
- four analog inputs 0–10 volts
- up to five analog outputs  
current:  $\pm 20$  mA,  
0–20 mA, 4–20 mA or  
voltage:  $\pm 10$  volt,  
0–10 volt
- up to five electrical isolated incremental counter inputs
- built-in apparatus with dimensions according to DIN

## Processor **SAB 80C 166 CPU**

<b>Power unit</b>	
Supply	24 VDC
Power input (power consumption)	according to the level of construction ca. 4.5 W until ca. 20 W
<b>General data</b>	
Display	two-line LC display with 16 characters each, character height 8 mm, illuminated background GREEN
Keyboard	18 mechanical short-stroke keys, stroke distance 0.5 mm
Housing	housing for switch panel plug-in unit made of plastic
Panel frame	144 x 144 mm, DIN 43700
Insertion depth	ca. 170 mm with plug board
Panel cutout	138 x 138 mm, tolerance + 0.8 x + 0.6 mm
Protection (DIN 40050)	IP 54 in appropriate switch panel mounting
Ground (weight)	according to the level of construction ca. 1 kg until 1.5 kg
<b>Relay contacts</b>	one normally-open-contact switching-time each
<b>Digital inputs</b>	electrical isolated by the optocoupler
Input impedance	$\geq 6 \text{ k}\Omega$
Input amplitude	low $\leq 10 \text{ volt}$ , high $\geq 12 \text{ volt}$
Switching time	typ. 1 ms
<b>Analogue inputs</b>	galvanical isolated for 24 volt supply
Input impedance	unit on: $> 20 \text{ k}\Omega$ unit off: $> 10 \text{ k}\Omega$
Signal selection	0 – 10 volt, 10 bit resolution
Protection wiring	protective circuit against excessive voltage, max. input voltage 30 volts
<b>Analogue outputs</b>	galvanical isolated for 24 volt supply
Voltage output	current or voltage output adjustable by means of jumper $\pm 10 \text{ volt}$ , 0 – 10 volt, 2 – 10 volt / load $\geq 1 \text{ k}\Omega$ , 12 bit resolution, short-circuit-proof
Current output	$\pm 20 \text{ mA}$ , 0 – 20 mA, 4 – 20 mA / load $\leq 250 \text{ Ohm}$ , 12 bit resolution, short-circuit-proof
<b>Volume counter inputs</b>	electrical isolated by the optocoupler
Input impedance	6 k $\Omega$
Input amplitude	low $\leq 11 \text{ volt}$ , high $\geq 13 \text{ volt}$
Rate-of-flow principle of measurement	period length measurement or gate time measurement
Maximum input frequency	$< 10 \text{ kHz}$
<b>Serial interfaces</b>	
<u>RS 232</u>	cable length $\leq 15 \text{ m}$
Input voltage	max. $\pm 30 \text{ V}$
Input current	typ. $\pm 3 \text{ mA}$ at $\pm 9 \text{ V}$ input voltage
Output current	typ. $\pm 3 \text{ mA}$
Adjustment (selection)	9600 Baud, 8 bit, no parity, 1 stop bit
Cable	shield data cables recommended
<u>RS 485</u>	electrical isolated by the optocoupler
Input impedance	$\geq 12 \text{ k}\Omega$
Adjustment (selection)	75, 600, 1200, 2400, 4800, 9600, 19200, 38400 baud 7 or 8 bit data width, selectable parity, 1 or 2 stop bits
Cable	shielded data cables, twisted pairs, recommended
<b>Environmental conditions</b>	
Operating temperature	0 °C up to + 50 °C
Storage temperature	-25 °C up to + 85 °C

# Type code ASR 16

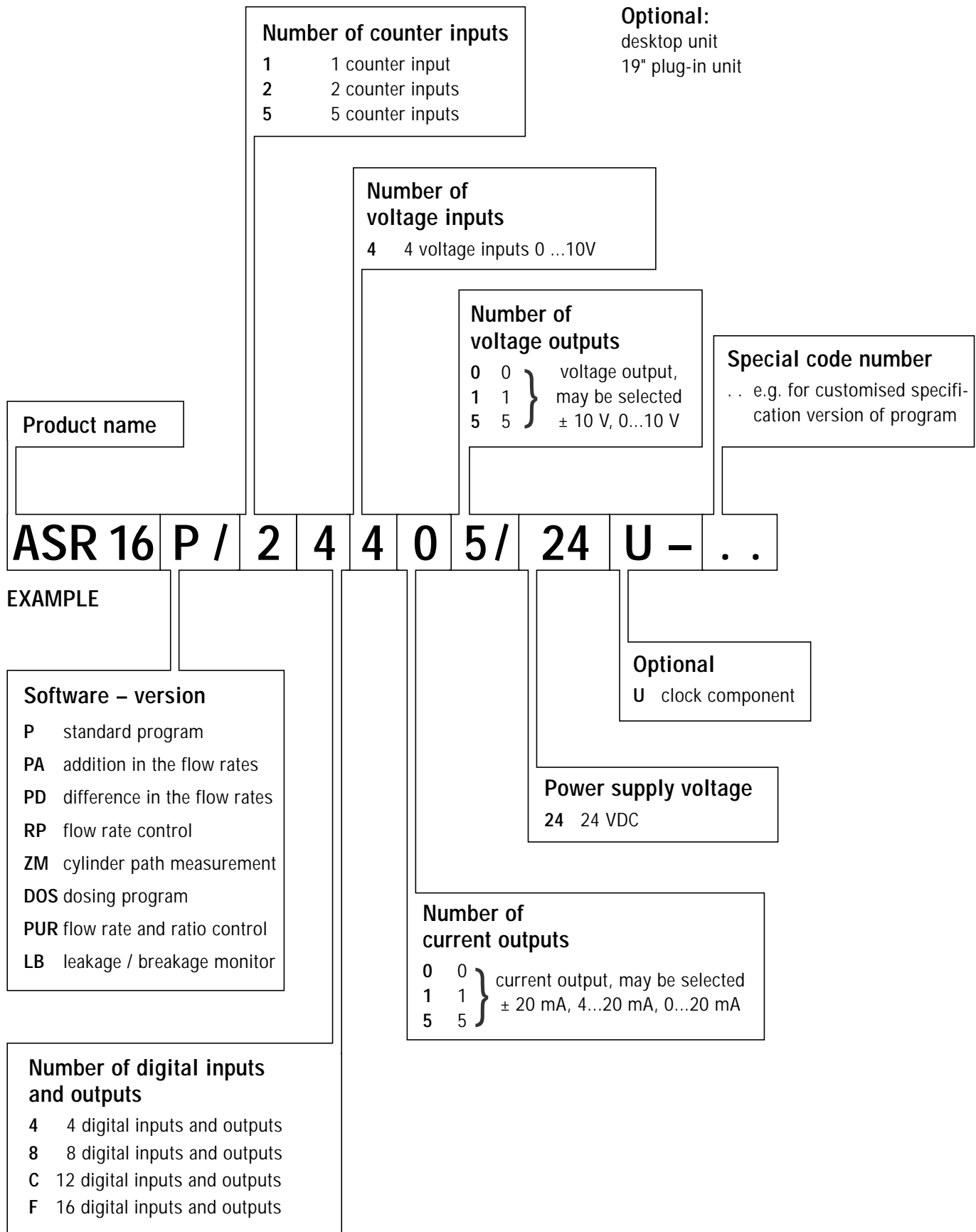

# Dimensions ASR 16

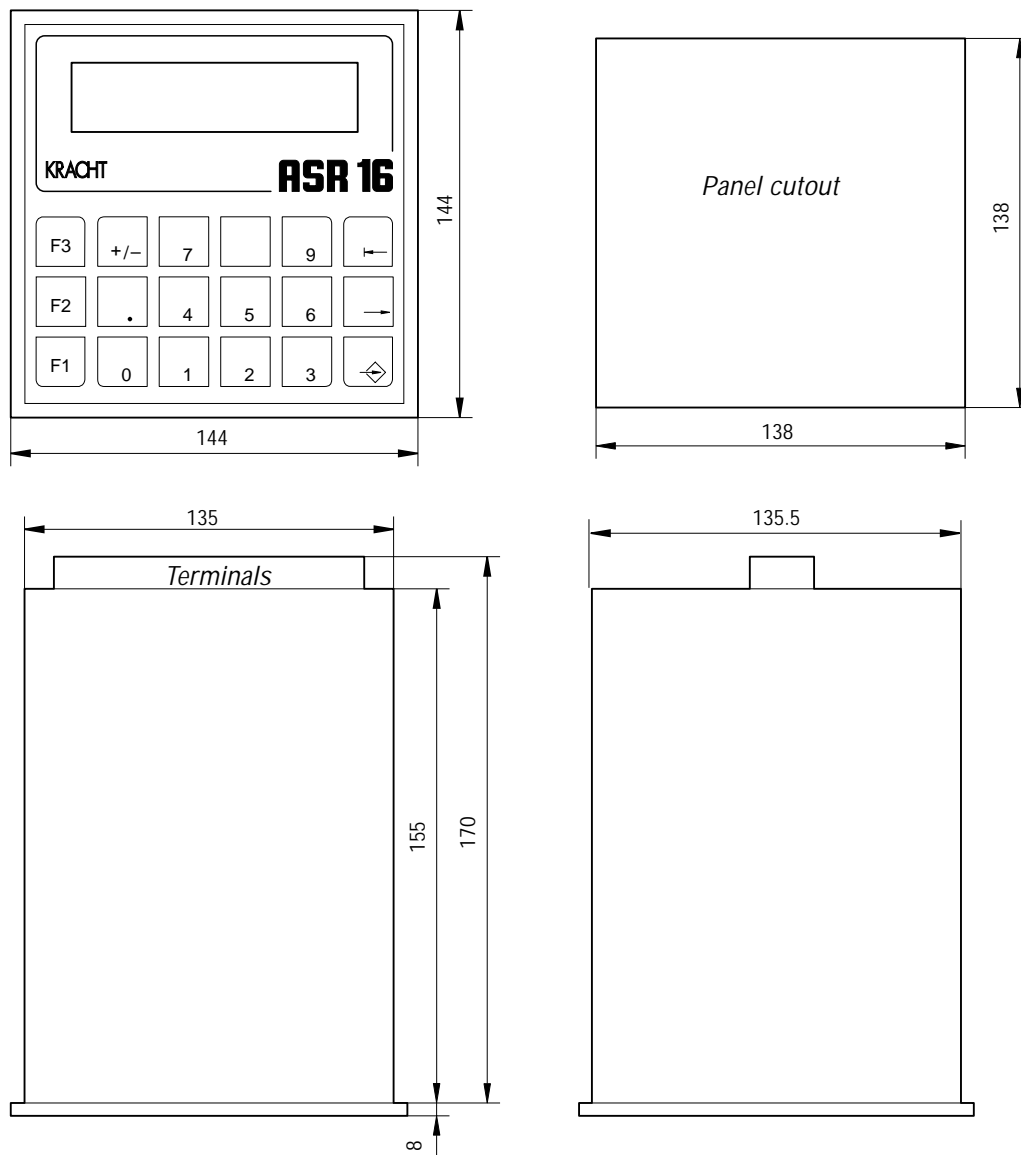

## Examples of application

- Flow rate measurement . . . . . test stand
- Volume measurement . . . . . consumption record
- Volume measurement . . . . . cylinder path measurement
- Synchronization control of cylinders . . . . . hydraulic units
- Dosing . . . . . filling units
- Flow rate control . . . . . multi-component units
- Control of the mixture ratio . . . . . multi-component units
- Leakage- / breakage control . . . . . hydraulic units

## Function and product characteristics ASR 20

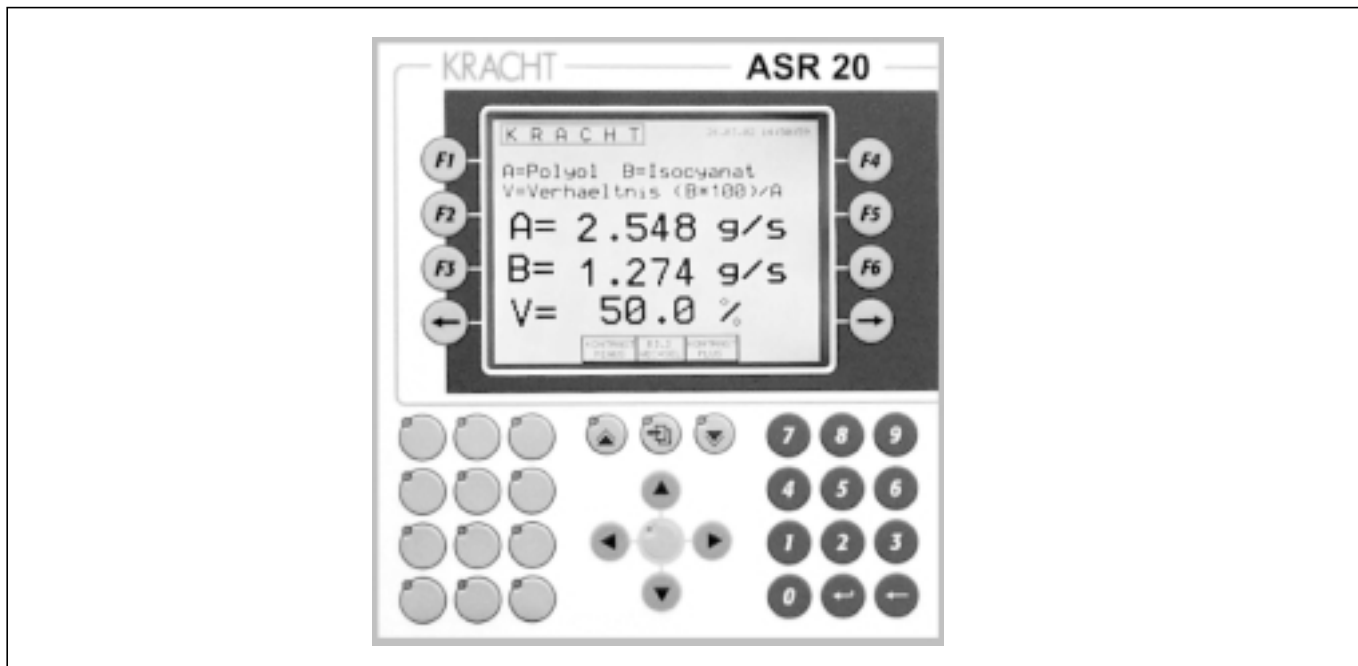

### Function

- The ASR 20 is a combination of operator panel and controller in one device. A lot of flow specific applications can be realized.
- The ASR 20 processes incremental signals.
- Standardized programs are available for a wide variety of applications.
- Standardized programs are available for different kind of applications.
- The number of in- and outputs can be adjusted to the specific application.
- Relay contacts, analogue outputs and serial interfaces are available for further external processing.
- The measured values are indicated on a LC-display.

### Product characteristics

- Used for KRACHT volume counters and other sensors with 24 V incremental signals.
- Up to 6 additional modules can be used.
- Analogue inputs allow the connection of pressure transducers, temperature sensors and the like.
- The input signals are filtered in the unit, interpreted and converted into the physical sizes flow rate and volume.

## Technical data ASR 20

### Power unit

Supply	24 VDC $\pm$ 25 %
Power consumption	max. 20 W

### General data

Display	5.7 Zoll QVGA (320 x 240 characters) black/white LC-display, illuminated background
Keyboard	8 softkeys and 32 function keys
Housing	housing for switch panel plug-in
Panel frame	205 x 220 mm (w x h)
Insertion depth	136 mm with plug board
Panel cutout	191 x 202 mm
Protection	IP 65 (front side)
Weight	approx. 1,95 kg

### Operating conditions

Mounting position	horizontal $\pm$ 45°
Ambient temperature	0 to 50 °C (depending on mounting)
Humidity when operating	10 to 90 % (not condensating)
Storage temperature	- 20 to 60 °C
Humidity at storage	5 to 95 % (not condensating)

### In- / outputs of the basic device

Digital inputs	10; 4 of these counter inputs (one channel)
Input voltage	24 V $\pm$ 25 %
Input current at 24 V	approx. 4 mA
Digital outputs	9; 1 of these relais contact
Switching voltage	24 V $\pm$ 25 %
Output current	max. 0.4 A

### Additional moduls

L.0090208203	Analogue input modul	1 x $\pm$ 10 V or 0 – 20 mA ( $\pm$ 20 mA possible) potentiometer operating, 12 bit resolution
L.0090208204	Analogue input modul	4 x $\pm$ 10 V, 12 bit resolution
L.0090209210	Analogue input modul	4 x 0 – 20 mA
L.0090208205	Analogue output modul	2 x $\pm$ 10 V or 0 – 20 mA (4 – 20 mA possible) 12 bit resolution
L.0090208206	Digital input modul	10 digital inputs 24 VDC
L.0090208208	Digital input modul	10 digital inputs, thereof 4 inputs for volume counters (one channel)
L.0090209213	Digital output modul	8 digital outputs 24 VDC / 0.5 A
L.0090208214	Temp.-input modul	2 x PT 100 3-line from - 200 °C to + 850 °C
L.0090209213	RS 232-modul	interface RS 232
L.0090209228	RS 485-modul	interface RS 485

# Dimensions ASR 20

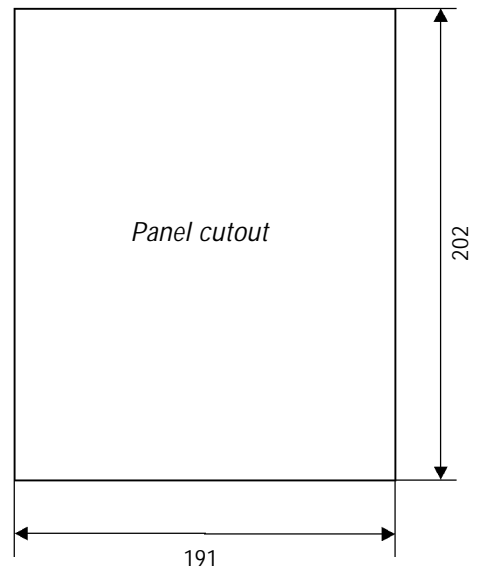
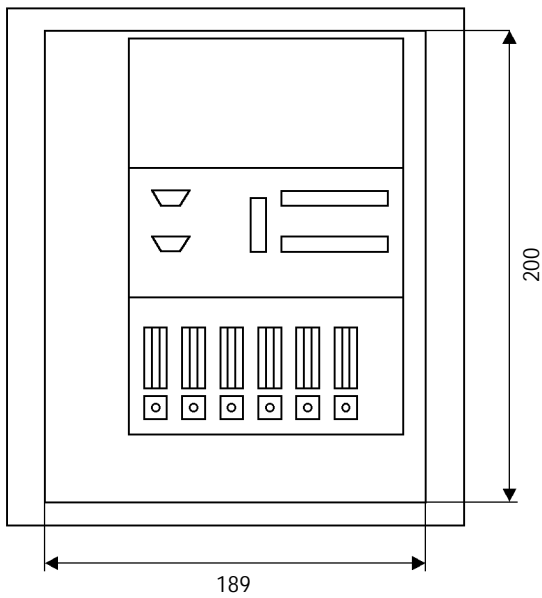
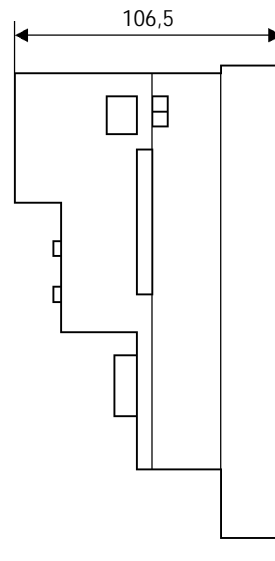
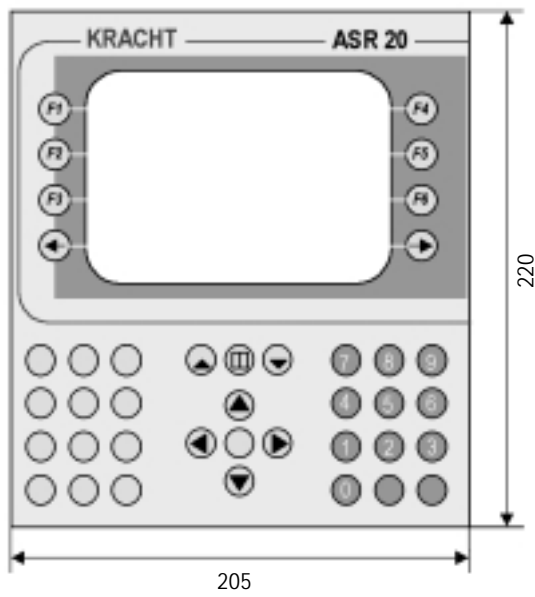

Dimensions in mm



## Overview of our complete program

### Transfer pumps

Transfer pumps for lubricating oil supply equipment, low pressure filling and feed systems, dosing and mixing systems.

### Mobile hydraulics

Single and multistage high pressure gear pumps, hydraulic motors and valves for construction machinery, lorry-mounted machines.

### Industrial hydraulics

Cetop directional control and proportional valves, hydraulic cylinders, pressure, quantity and stop valves for pipe and slab construction, hydraulic accessories for industrial hydraulics (mobile and stationary use).

### Volutronic®

Gear flow meters and electronics for volume and flow metering technology in hydraulics, processing and laquering technology.

With our decades of experience, we are at your side, world-wide, for the professional mastery of specific applications and complete solutions in hydraulics and process technology.



Elektronik / e / 03.2003