

KRACHT

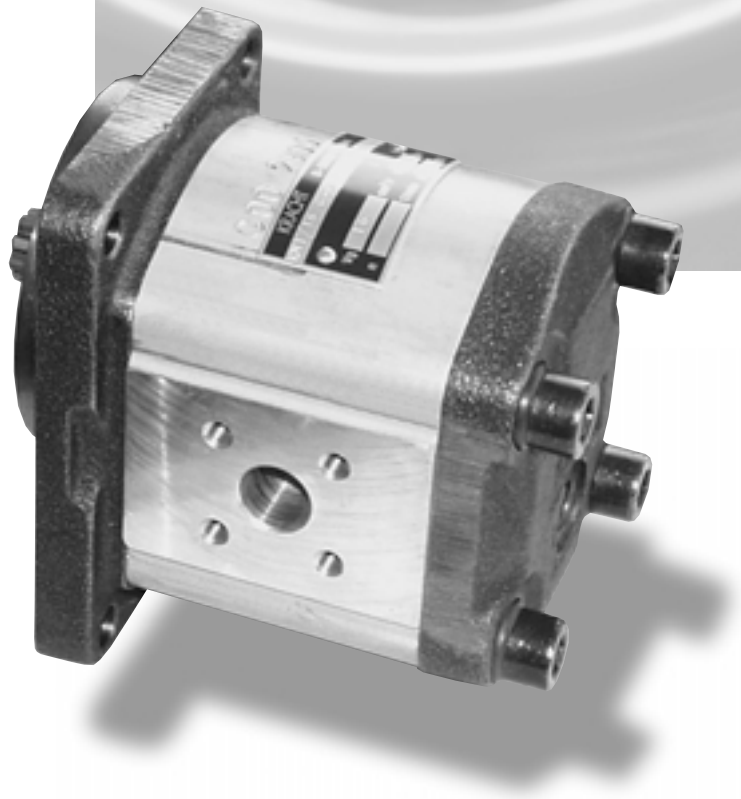

High Pressure Gear Motors KM 1

Construction of High Pressure Gear Motors, Series KM 1

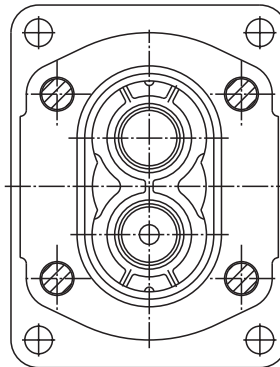
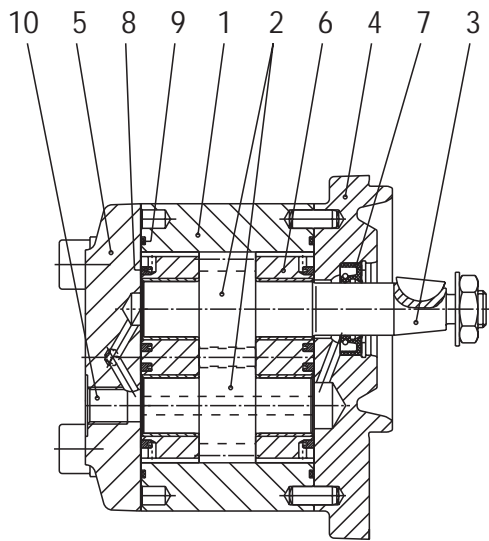

- 1 Housing
- 2 Gearing
- 3 Drive Shaft End
- 4 Flange Mounting Cover
- 5 End Cover
- 6 Double Gland Bearing with special plane bearing bushes
- 7 Rotary Shaft Lip-Type Seals
- 8 Pressure Field Sealing for axial clearance compensation
- 9 Sealing of the Housing
- 10 Drain port

Description

Accordingly to its configuration – the Design principle is illustrated by the Sectional figure above – the Kracht External Gear-Type Motor Series KM 1 is classified in the category of the so-called Gland-Type Bearing Motors.

All essential functional parts as the gearing and the gland bearings are located in an aluminium housing manufactured of a high strength extrusion alloy which is closed on each side by an end cover or by a flange mounting cover respectively.

The gearing of case hardening steel in surface hardened condition consists of the pinion shaft and the pinion. Highest manufacturing quality is assured by grinding and honing of the tooth flanks.

The surfaces of the journals are superfinished.

An important reduction of the type dependent deviation of the volumetric flow and of the pressure pulsation was achieved on the basis of the great teeth number ($z = 13$) and the specially shaped teeth. The gland bearings located on both sides of the gearing carry the journals in heavyduty multicomponent plane bearing bushes and contain additionally those sealing elements which serve for the pressure field sealing to compensate the axial clearance.

The optimal design of the pressure fields guarantees very good efficiencies over a wide pressure/speed-range on the one hand – at the nominal operating point for instance a total efficiency of 90 % and above is reached – and ensures a smooth starting behaviour of the motor on the other hand and that already at a low rate of the input flow.

As the pressure fields are symmetrically arranged the motors can be used as well for clockwise as for anticlockwise rotation (reversible operating modes).

The pressure relief of the shaft seal is effected by the drain

port to be found in the end cover, (note the max. permissible drain pressure) so that the motors may be pressurized at the outlet side, hence follows that it is possible to connect together several motors in series.

For high speed Operation the shaft seal must be of FPM-material (Viton), refer to page 5.

The combination of 2 motors for instance coupled together and provided with a common supply line makes a Flow Divider with a high dividing accuracy.

Special Note:

External Loads

Radial or Axial loads acting on the shaft end impair the functions of the gland bearings. Radial loads can possibly be absorbed in dependence on the extent and the direction of the loads.

Axial loads are NOT permissible.

To absorb external loads the motor type with outboard bearing must be used.

Characteristics

General Characteristics

Mounting	Flange and Foot-Type
Pipe Connection	Flange-Type
Direction of Rotation	Clockwise and Anticlockwise
Weight	refer to Dimensional Sheet
Fitting Position	Optional
Permissible Ambient Temperature Range	$\vartheta_{u \min} = - 20 \text{ }^{\circ}\text{C}$ $\vartheta_{u \max} = + 60 \text{ }^{\circ}\text{C}$

Operating Characteristics

Operating Pressures

Input Side	$p_{1 \max} =$ refer to technical data
Outlet Side	$p_{2 \max} = 120 \text{ bar}$
Drain Pressure	$p_{T \max} = 2 \text{ bar}$
Short Time	$p_{T \max} = 5 \text{ bar}$

Fluid Temperature Range	$\vartheta_{m \max} = 90 \text{ }^{\circ}\text{C}$ for NBR-Rotary Shaft Lip-Type Seal $100 \text{ }^{\circ}\text{C}$ for FPM-Rotary Shaft Lip-Type Seal
-------------------------	--

Viscosity Range	$v_{\min} = 10 \text{ mm}^2/\text{s}$ $v_{\max} = 600 \text{ mm}^2/\text{s}$
-----------------	---

Filtration	ISO/DIS 4406 Code 19/16 \cong NAS 1638 Class 10
------------	--

Grade of Filtration	$\beta_{25} \geq 75$ for ... 300 bar $\beta_{40} \geq 75$ for ... 100 bar
---------------------	--

Recommended Viscosity Range	$v = 30 \dots 45 \text{ mm}^2/\text{s}$
-----------------------------	---

Characteristic Curves	refer to pages 5 – 8
-----------------------	----------------------

Hydraulic Fluids	Mineral Oil acc. DIN 51524/25 Mineral Oil acc. DIN 51511 Bio-oils of type „HEES“, can be used up to $70 \text{ }^{\circ}\text{C}$, max. pressure must be reduced minus 20% (use only on request)
------------------	---

Materials

Housing	Aluminium-Alloy
Bearing	Double Gland Bearing with Multi-component Plane Bearing Bushes
Journals and Gears	Case Hardening Steel acc. to DIN 17210 Surface Hardened and Ground
Seals	1 NBR Rotary Shaft Lip-Type Seal $\vartheta \leq 90 \text{ }^{\circ}\text{C}$ (PU-Sealing for pressure field) 2 FPM Rotary Shaft Lip-Type Seal $\vartheta \leq 100 \text{ }^{\circ}\text{C}$ (PU-Sealing for pressure field)

Technical Data

Nominal Motor-Displacement	Geom. Motor-Displacement	max. Pressure	Rated Pressure	Continuous Operating Pressure	max. Operating Speed	Moment of Inertia x 10 ⁻⁶	
V_g	p_{max}	p_N	p_D	n_{max}	J		
cm ³ /r	bar	bar	bar	rpm	kg m ²		
				NBR	FPM		
5.5	5.45	300	280	250	3000	4000	35.7
6.3	6.28	300	280	250	3000	4000	39.9
8	7.9	300	280	250	3000	4000	51.1
9.6	9.59	300	280	250	3000	4000	56.5
11	10.9	300	280	250	3000	4000	62.9
14	13.85	300	280	250	3000	4000	77.7
16	15.9	260	240	210	3000	4000	87.7
19	18.8	220	200	180	3000	4000	102.5
22	22.3	200	180	150	3000	4000	119.6

Time / Pressure Chart

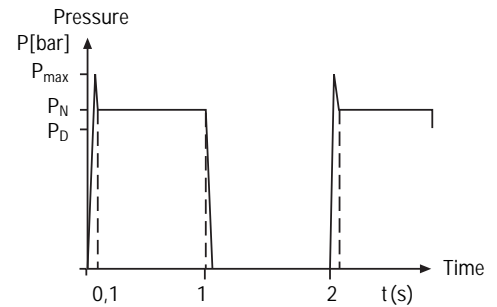

Maximum Pressure $\hat{=}$ Pressure-Peak
 Rated Pressure $p_N < 6s \hat{=}$ 50% ED
 see Time / Pressure Chart
 max. Permissible Operating Cycles: 30 / min
 Pressures as specified
 are applicable to $v \hat{=}$ 30 mm²/s

Calculation Formulas for Hydraulic Pumps and Motors

Characteristic Data, Formula Signs, Units

1. Discharge Flow / Input Flow	Q	l/min
2. Pump / Motor Displacement	V_g	cm ³ /r
3. Pressure	p	bar
4. Speed of Rotation	n	rpm
5. Torque	M	Nm
6. Power	P	kW
7. Total Efficiency	η_{tot}	—
8. Volumetric Efficiency	η_{vol}	—
9. Hydr./Mech. Efficiency	η_{hm}	—
10. Flow Velocity	v	m/s
11. Piping Diameter	d	mm

General

1 $\hat{=}$ Input, Driven 2 $\hat{=}$ Output, Driving

$$Q_{th} = V_g \cdot n, \quad \eta_{tot} = \eta_{vol} \cdot \eta_{hm}$$

$$M = 9549 \cdot \frac{P}{n}, \quad v = 21.22 \frac{Q}{d^2}$$

Approximate Values for Kracht Products
 in the Nominal Operating Point

	η_{tot}	η_{vol}
KP	≈ 0.90	≈ 0.95
KM	≈ 0.85	≈ 0.90

Characteristic Data for:	Volumetric-Flow	Discharge Flow $Q_2 = \frac{V_g \cdot n_1 \cdot \eta_{vol}}{10^3} \left[\frac{l}{min} \right]$	Input Flow $Q_1 = \frac{V_g \cdot n_2}{10^3 \cdot \eta_{vol}} \left[\frac{l}{min} \right]$
	Torque	Drive Torque $M_1 = \frac{p \cdot V_g}{20 \cdot \pi \cdot \eta_{hm}} \text{ [Nm]}$	Output Torque $M_2 = \frac{\Delta p \cdot V_g \cdot \eta_{hm}}{20 \cdot \pi} \text{ [Nm]}$
	Power	Input Power $P_1 = \frac{p \cdot Q_2}{600 \cdot \eta_{tot}} \text{ [kW]}$	Output Power $P_2 = \frac{\Delta p \cdot Q_1 \cdot \eta_{tot}}{600} \text{ [kW]}$

Characteristic Curves

Characteristic Curves for type KM 1/5.5

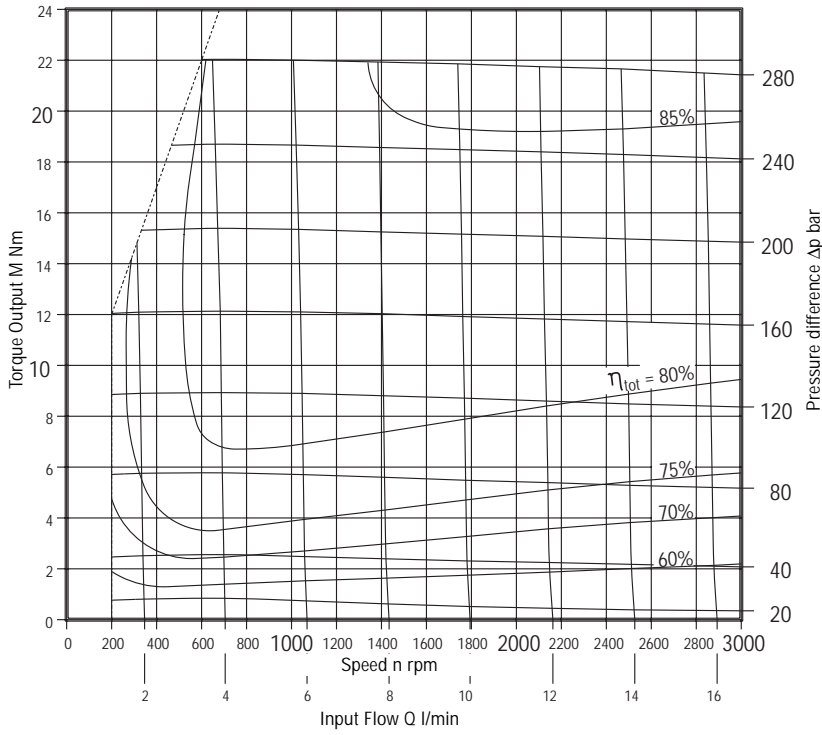

Characteristic values applicable to viscosity $\nu = 34 \text{ mm}^2/\text{s}$
 Dispersion of the speed values $n = \pm 75 \text{ rpm}$
 Dispersion of the torque output $M = \pm 1.1 \text{ Nm}$
 at $\Delta p = \text{constant}$ and $Q = \text{constant}$

Characteristic Curves for type KM 1/8

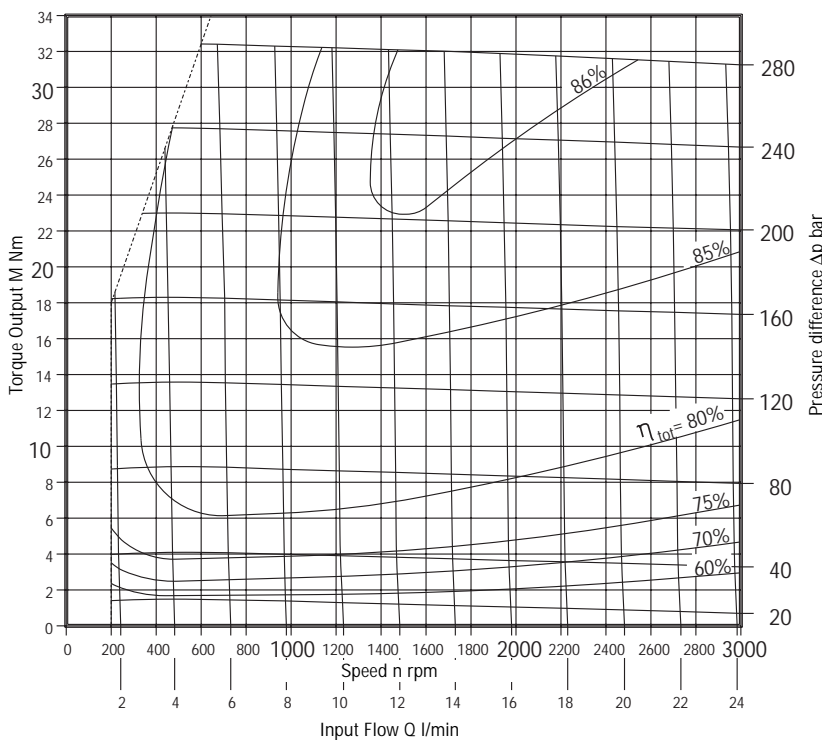

Characteristic values applicable to viscosity $\nu = 34 \text{ mm}^2/\text{s}$
 Dispersion of the speed values $n = \pm 75 \text{ rpm}$
 Dispersion of the torque output $M = \pm 1.6 \text{ Nm}$
 at $\Delta p = \text{constant}$ and $Q = \text{constant}$

Characteristic Curves

Characteristic Curves for type KM 1/11

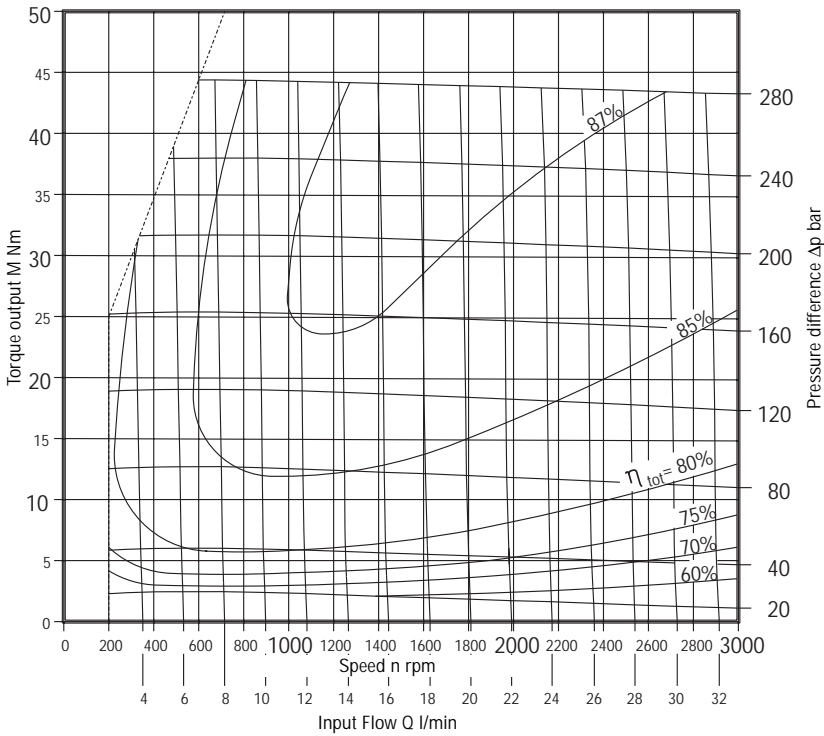

Characteristic values applicable to viscosity $\nu = 34 \text{ mm}^2/\text{s}$
 Dispersion of the speed values $n = \pm 75 \text{ rpm}$
 Dispersion of the torque output $M = \pm 2.2 \text{ Nm}$
 at $\Delta p = \text{constant}$ and $Q = \text{constant}$

Characteristic curves for type KM 1/14

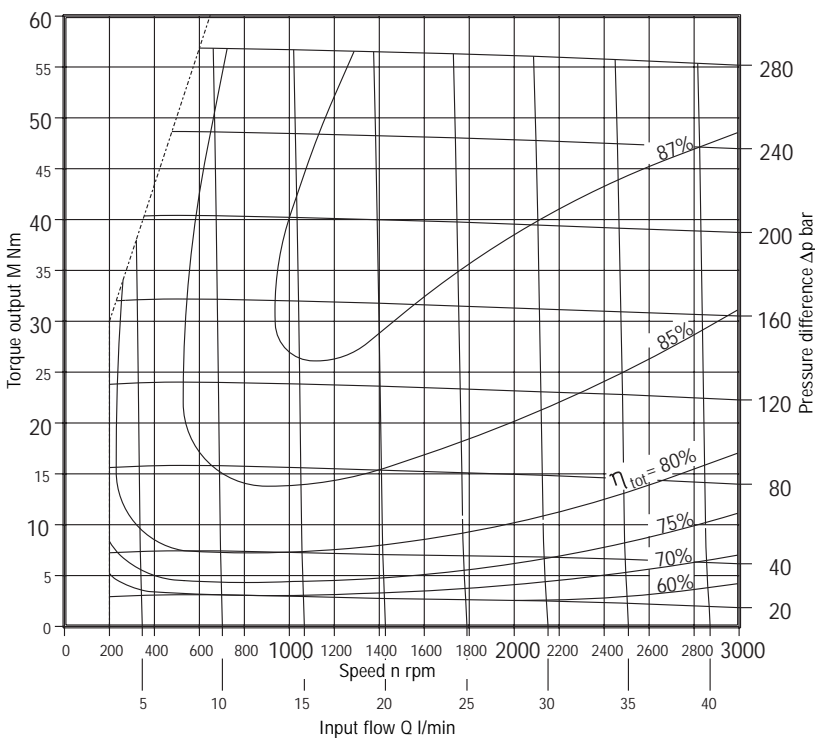

Characteristic values applicable to viscosity $\nu = 34 \text{ mm}^2/\text{s}$
 Dispersion of the speed values $n = \pm 75 \text{ rpm}$
 Dispersion of the torque output $M = \pm 2.8 \text{ Nm}$
 at $\Delta p = \text{constant}$ and $Q = \text{constant}$

Characteristic Curves

Characteristic curves for type KM 1/16

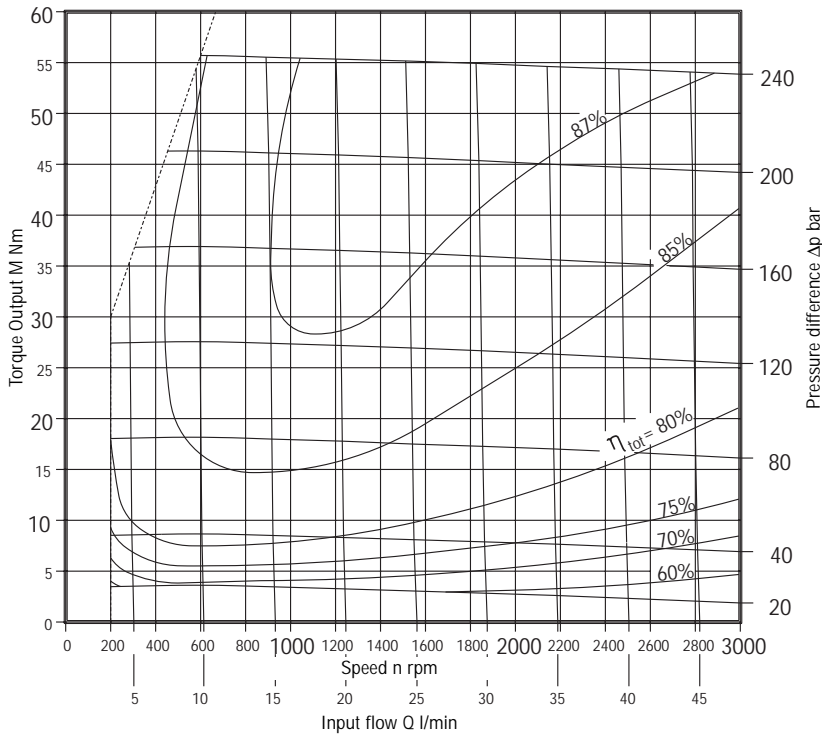

Characteristic values applicable to viscosity $\nu = 34 \text{ mm}^2/\text{s}$
 Dispersion of the speed values $n = \pm 75 \text{ rpm}$
 Dispersion of the torque output $M = \pm 2.8 \text{ Nm}$
 at $\Delta p = \text{constant}$ and $Q = \text{constant}$

Characteristic curves for type KM 1/19

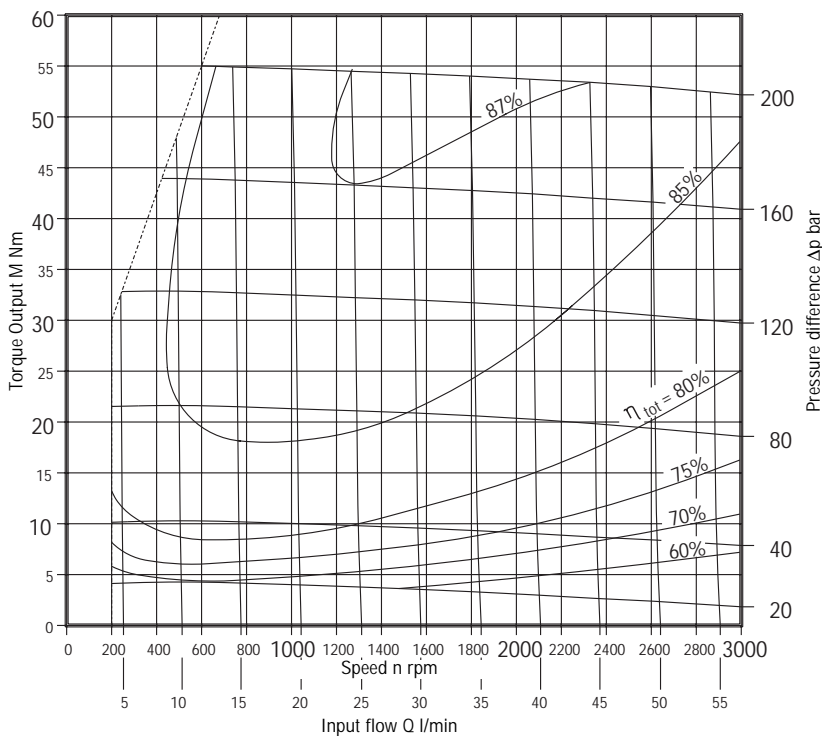

Characteristic values applicable to viscosity $\nu = 34 \text{ mm}^2/\text{s}$
 Dispersion of the speed values $n = \pm 75 \text{ rpm}$
 Dispersion of the torque output $M = \pm 2.8 \text{ Nm}$
 at $\Delta p = \text{constant}$ and $Q = \text{constant}$

Characteristic Curves

Characteristic curves for type KM 1/22

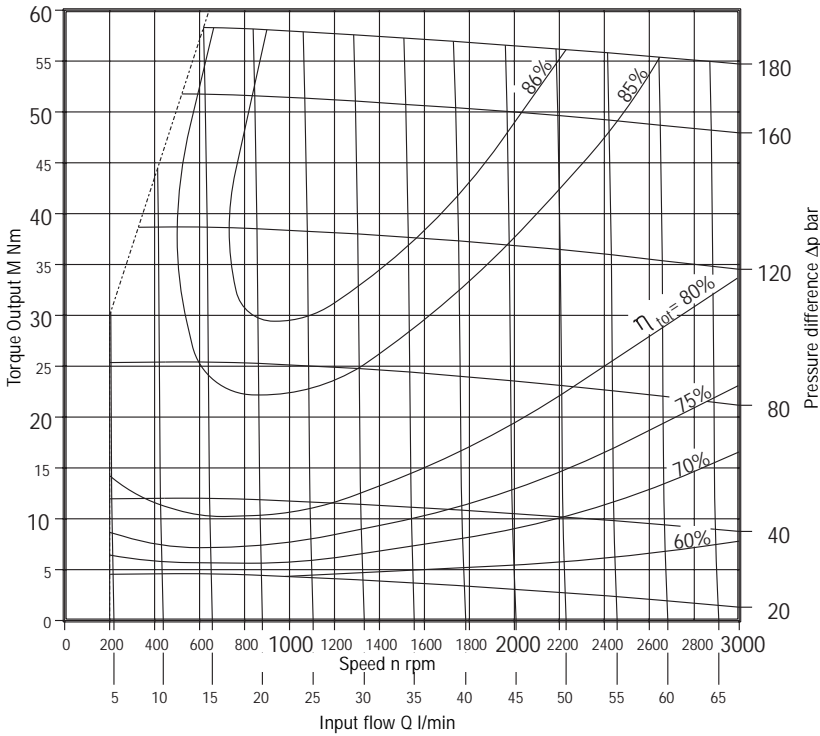

Characteristic values applicable to viscosity $\nu = 34 \text{ mm}^2/\text{s}$
 Dispersion of the speed values $n = \pm 75 \text{ rpm}$
 Dispersion of the torque output $M = \pm 2.8 \text{ Nm}$
 at $\Delta p = \text{constant}$ and $Q = \text{constant}$

Guidance for use of the Characteristic Curves

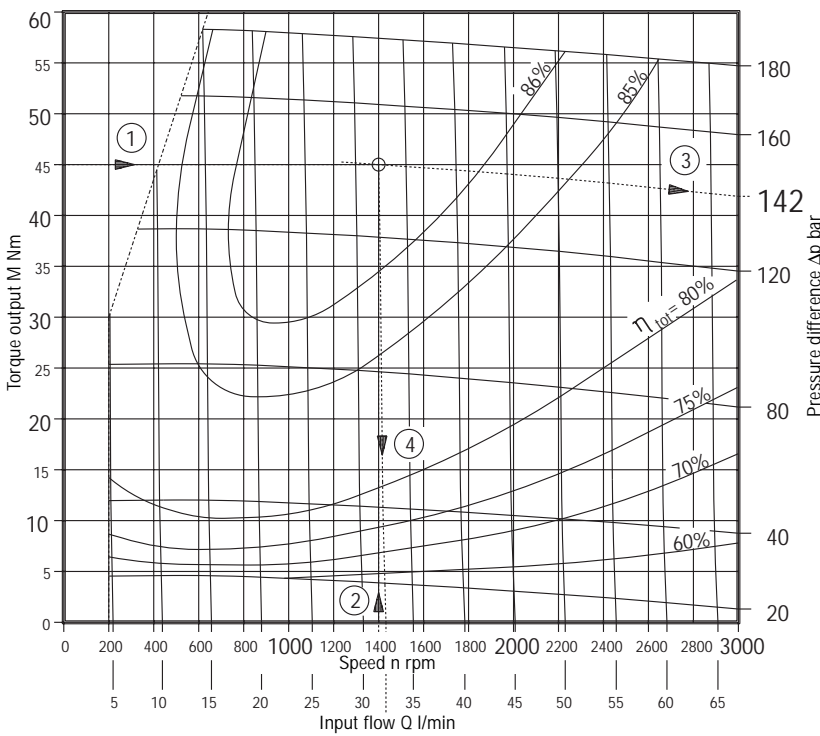

Required: Torque Output M at Speed n
 Unknown: Pressure Difference Δp and the required Input flow Q
 Example: $M = 45 \text{ Nm}$ → ①
 $n = 1400 \text{ rpm}$ ↑ ②
 The Intersection of ① und ② is the motor operating point with:
 $\Delta p = 142 \text{ bar}$ → ③
 $Q = 32,2 \text{ l/min}$ ↓ ④

32,2

Type-Key

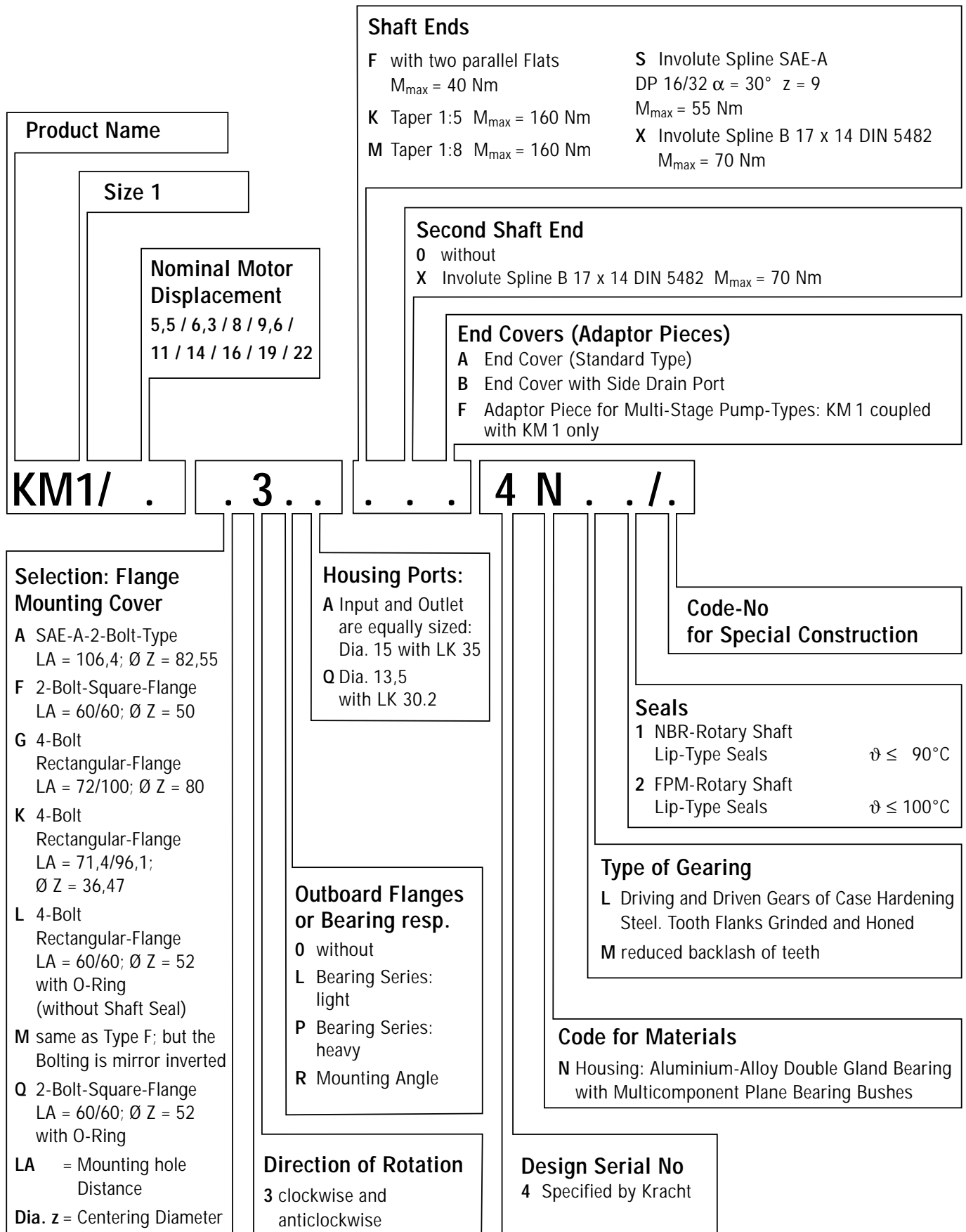

High Pressure Gear Motors KM 1

G-Flange, Tapered Shaft End

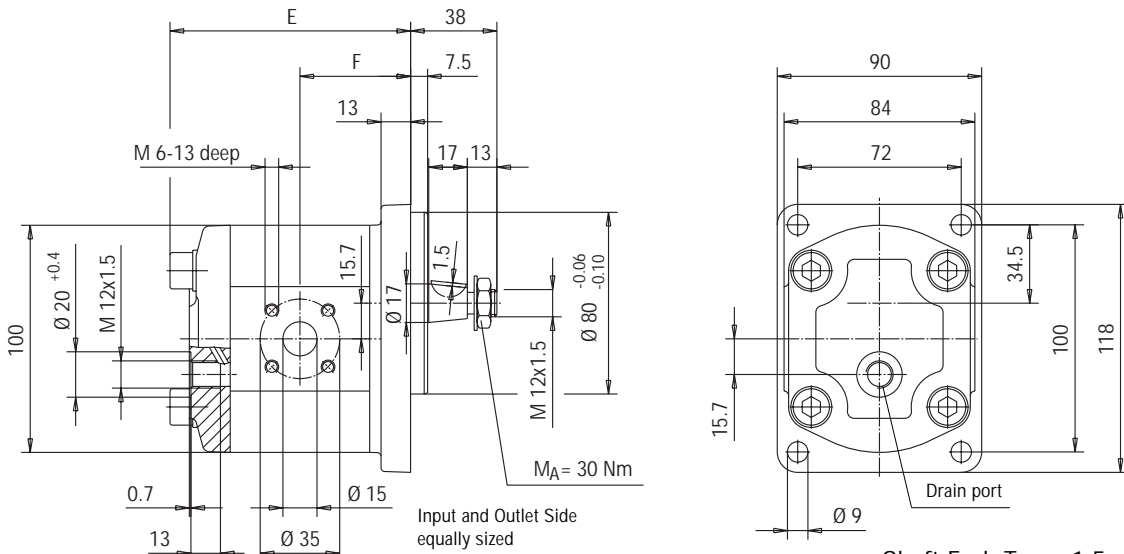

Ordering Code:
KM 1/8 G30A KOA 4NL1

Shaft End: Taper 1:5
Hex. Lock Nut M 12 x 1.5
DIN EN 28675
Curved Spring washer B12 DIN 137
Woodruff key 3 x 6.5 DIN 6888

G-Flange, Involute Spline Shaft End

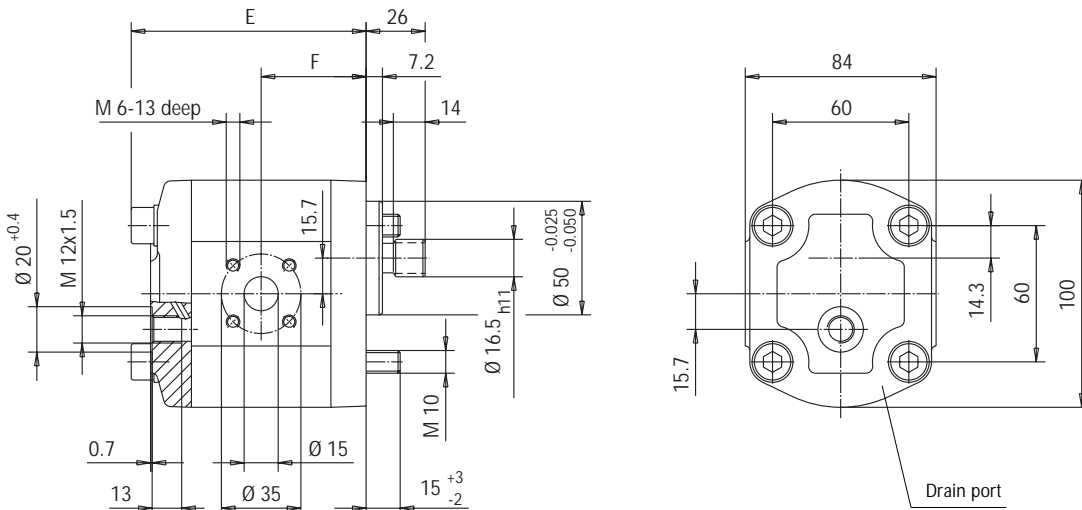

Ordering Code
KM 1/8 G30A XOA 4NL1

Shaft End: Involute Splinge
B 17 x 14 DIN 5482
but tooth thickness $S_w = 3.206$
Addendum Modification = +0.6

Nominal Displacement	5.5	6.3	8	9.6	11	14	16	19	22
E	91.7	93.1	95.9	98.7	100.9	105.9	109.3	114.3	120.1
F	41.6	42.3	43.7	45.1	46.2	48.7	50.4	52.9	55.8
Weight kg	2.2	2.3	2.3	2.4	2.5	2.6	2.8	2.9	3.1

High Pressure Gear Motors KM 1

End Cover B

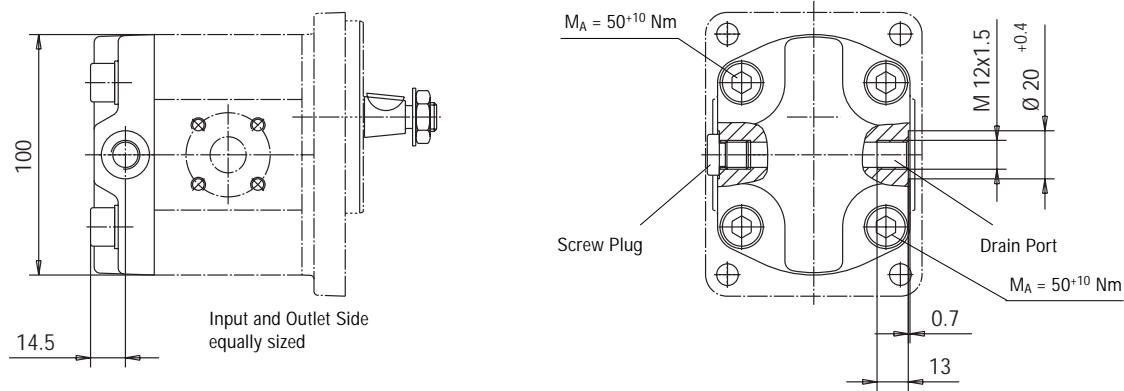

End Cover B
available for all types of motor.
Connection of the drain piping
optional on the right or left side.

SAE A-Flange, Tapered Shaft End

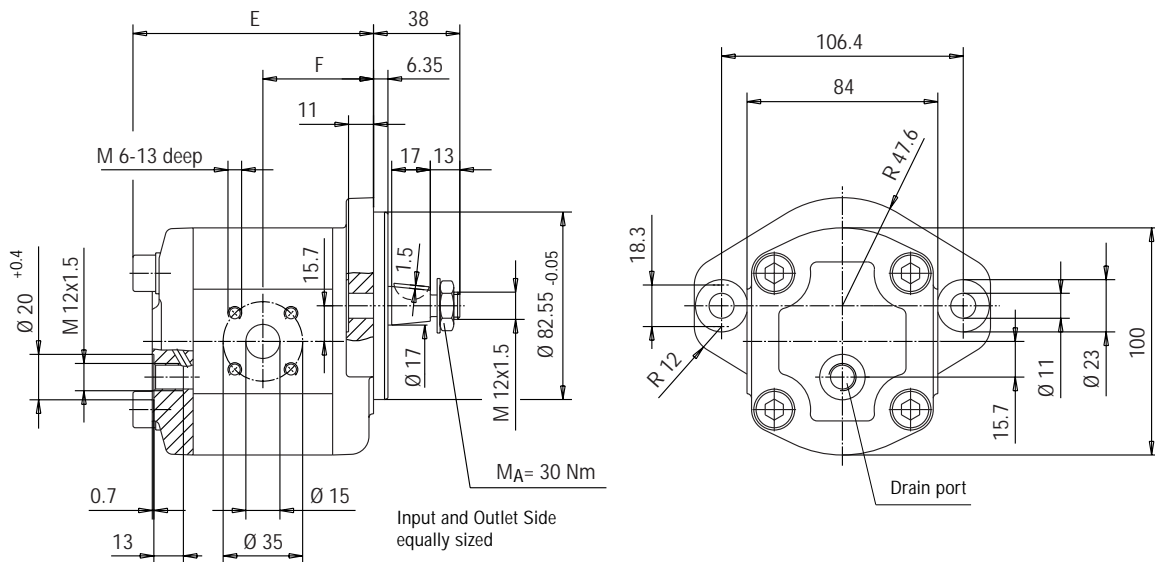

Ordering Code:
KM 1/8 A30A KOA 4NL1

Shaft End: Taper 1:5
Hex. Lock Nut M 12 x 1.5
DIN EN 28675
Curved Spring washer B12 DIN 137
Woodruff key 3 x 6.5
DIN 6888

High Pressure Gear Motors KM 1

SAE A-Flange, SAE A-Shaft-End

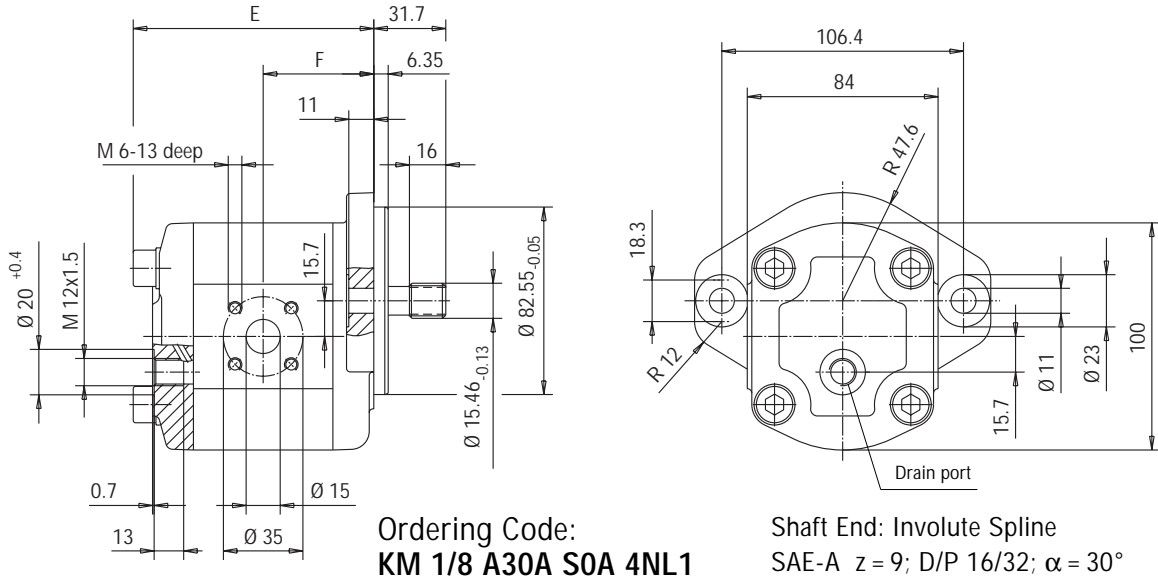

SAE A-Flange, Involute Spline Shaft End

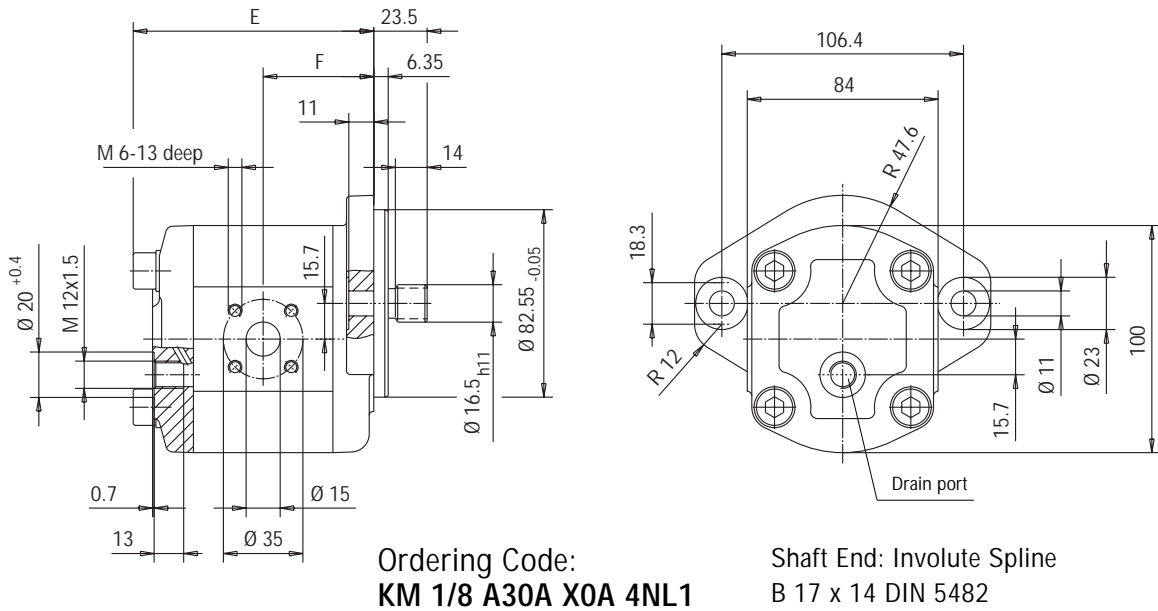

Nominal Displacement	5.5	6.3	8	9.6	11	14	16	19	22
E	91.7	93.1	95.9	98.7	100.9	105.9	109.3	114.3	120.1
F	41.6	42.3	43.7	45.1	46.2	48.7	50.4	52.9	55.8
Weight kg	2.6	2.7	2.7	2.8	2.9	3.0	3.2	3.3	3.5

High Pressure Gear Motors KM 1

K-Flange, Tapered Shaft End 1:8

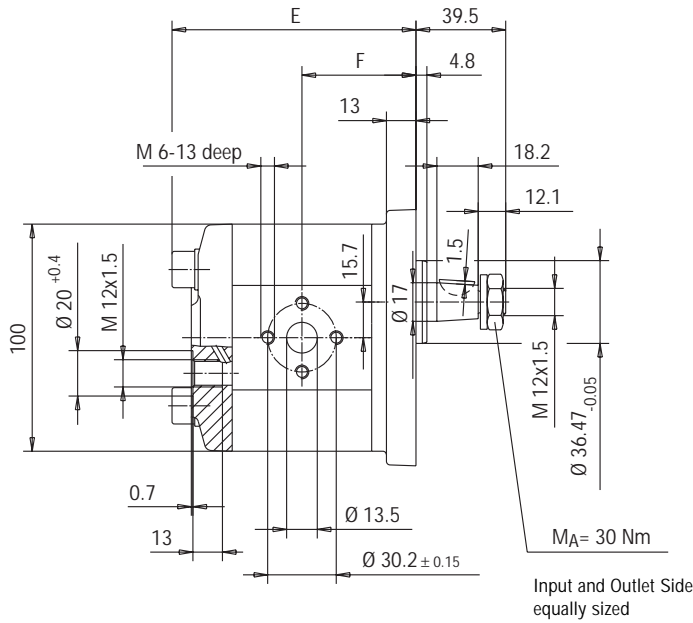

Shaft End: Taper 1:8
 Hex. Lock Nut M 12 x 1.5
 DIN EN 28675
 Curved Spring washer B12
 DIN 137
 Woodruff key 3 x 6.5
 DIN 6888

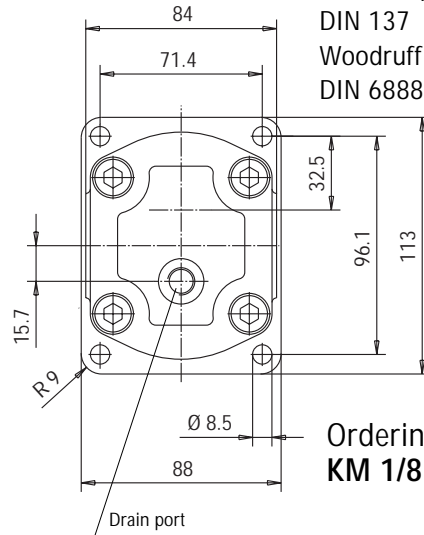

Ordering Code:
KM 1/8 K30Q M0A 4NL1

K-Flange, Involute Spline Shaft End

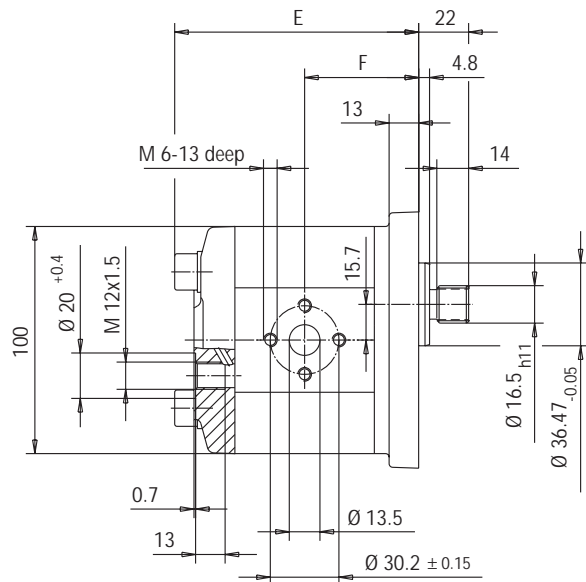

Shaft End: Involute Spline
 B 17 x 14 DIN 5482
 but tooth thickness $S_w = 3.206$
 Addendum Modification = +0.6

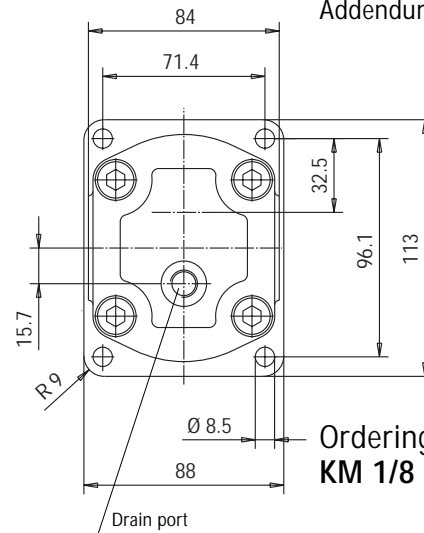

Ordering Code:
KM 1/8 K30Q X0A 4NL1

Nominal Displacement	5.5	6.3	8	9.6	11	14	16	19	22
E	93.2	94.6	97.4	100.2	102.4	107.4	110.8	115.8	121.6
F	43.1	43.8	45.2	46.6	47.7	50.2	51.9	54.4	57.3
Weight kg	2.2	2.3	2.3	2.4	2.5	2.6	2.8	2.9	3.1

High Pressure Gear Motors KM 1

M-Flange, Tapered Shaft End

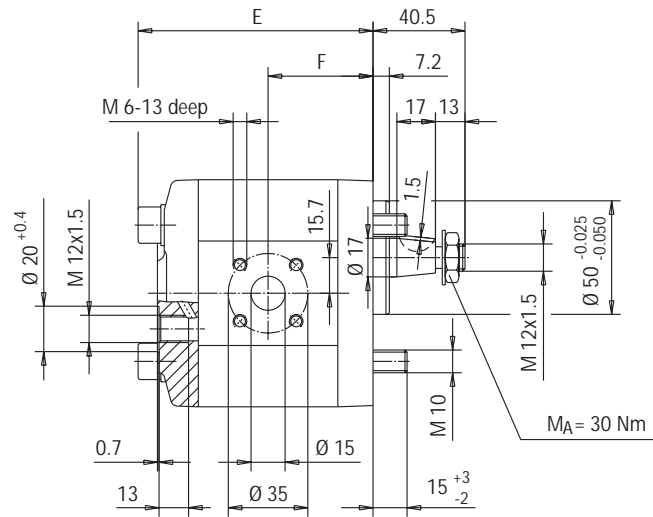

Shaft End: Taper 1:5
 Hex. Lock Nut M 12 x 1.5
 DIN EN 28675
 Curved Spring washer B12 DIN 137
 Woodruff key 3 x 6.5
 DIN 6888

Ordering Code:
KM 1/8 M30A KOA 4NL1

M-Flange, Involute Spline Shaft End

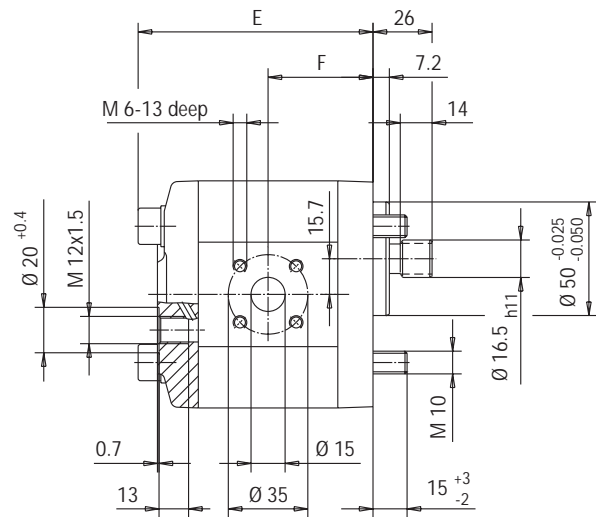

Shaft End: Involute Spline
 B 17 x 14 DIN 5482
 but tooth thickness $S_w = 3.206$
 Addendum Modification = +0.6

Ordering Code:
KM 1/8 M30A XOA 4NL1

Nominal Displacement	5.5	6.3	8	9.6	11	14	16	19	22
E	89.2	90.6	93.4	96.2	98.4	103.4	106.8	111.8	117.6
F	39.1	39.8	41.2	42.6	43.7	46.2	47.9	50.4	53.3
Weight kg	2.2	2.3	2.3	2.4	2.5	2.6	2.8	2.9	3.1

High Pressure Gear Motors KM 1

Q-Flange, Tapered Shaft End

Shaft End: Taper 1:5
 Hex. Lock Nut M 12 x 1.5
 DIN EN 28675
 Curved Spring washer B12 DIN 137
 Woodruff key 3 x 6.5
 DIN 6888

Ordering Code:
KM 1/8 Q30A KOA 4NL1

Q-Flange, Involute Spline Shaft End

Shaft End: Involute Spline
 B 17 x 14 DIN 5482
 but tooth thickness $S_w = 3.206$
 Addendum Modification = +0.6

Ordering Code:
KM 1/8 Q30A XOA 4NL1

Nominal Displacement	5.5	6.3	8	9.6	11	14	16	19	22
E	89.2	90.6	93.4	96.4	98.4	103.4	106.8	111.8	117.6
F	39.1	39.8	41.2	42.6	43.7	46.2	47.9	50.4	53.3
Weight kg	2.2	2.3	2.3	2.4	2.5	2.6	2.8	2.9	3.1

High Pressure Gear Motors KM 1

L-Flange, Parallel Flat Shaft End

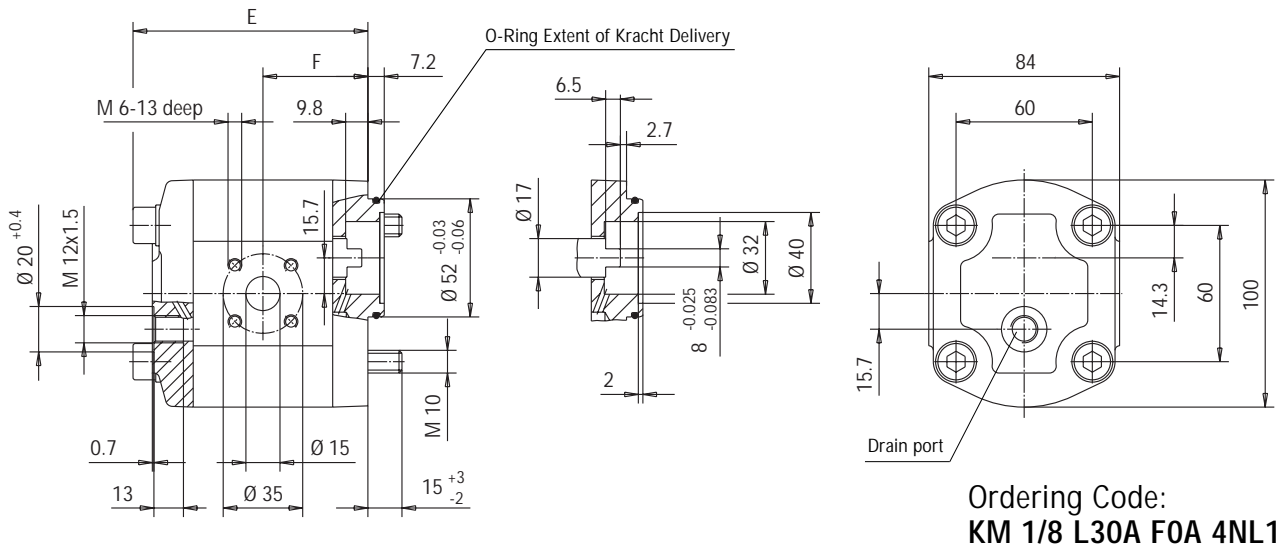

L-Flange, Involute Spline Shaft End

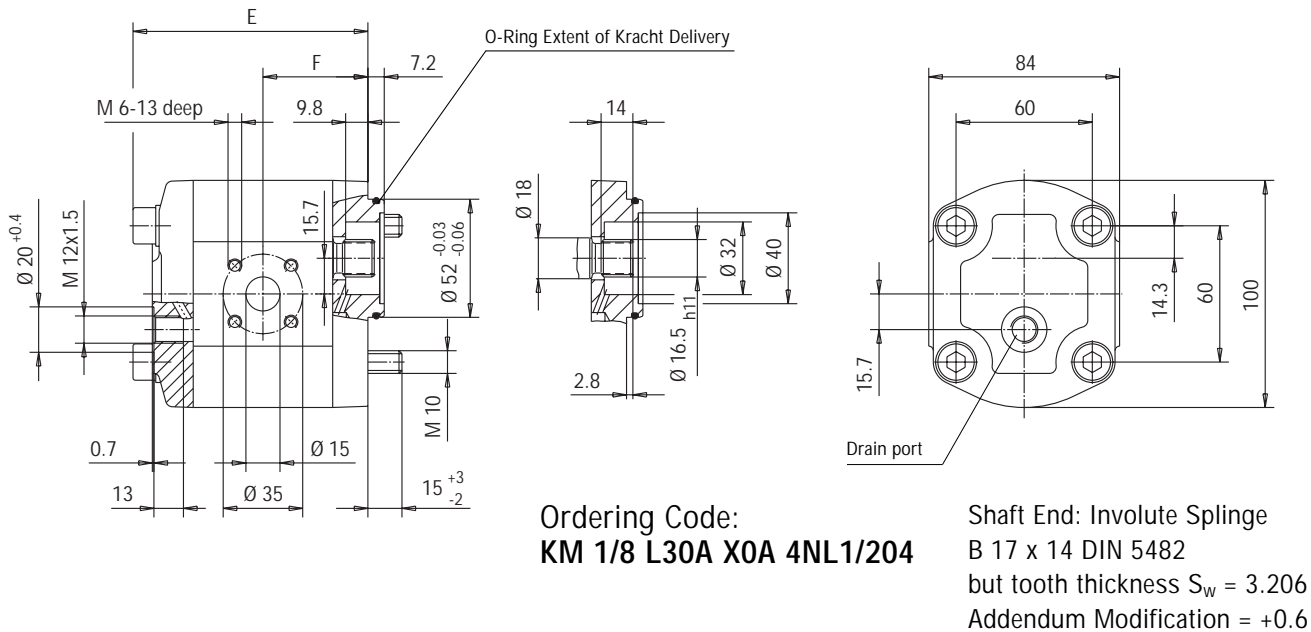

Nominal Displacement	5.5	6.3	8	9.6	11	14	16	19	22
E	89.2	90.6	93.4	96.2	98.4	103.4	106.8	111.8	117.6
F	39.1	39.8	41.2	42.6	43.7	46.2	47.9	50.4	53.3
Weight kg	2.2	2.3	2.3	2.4	2.5	2.6	2.8	2.9	3.1

High Pressure Gear Motors KM 1

Outboard Bearing L, Tapered Shaft End

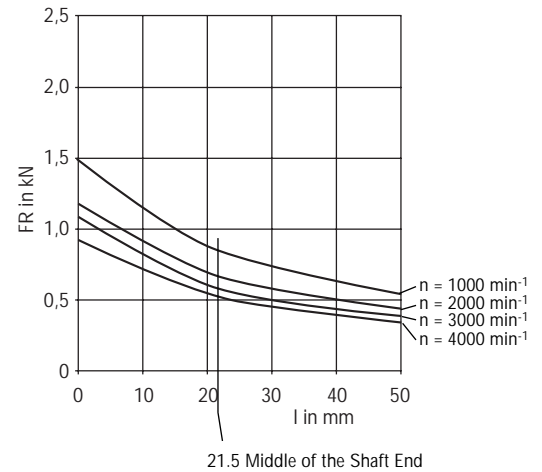
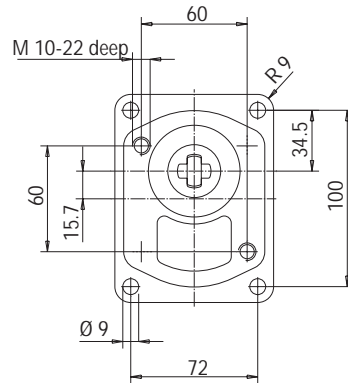
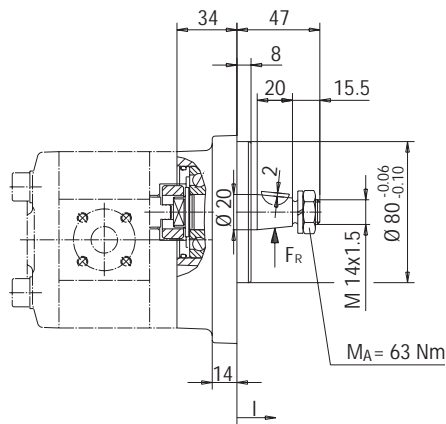

Ordering Code: **KM 1/4 L1LA FOA 4NL1**

Weight of the Outboard Bearing = 1.0 kg

Shaft End: Taper 1:5
 Hex. Lock Nut M 14 x 1.5
 DIN EN 28675
 Curved Spring washer
 B12 DIN 127
 Woodruff key 4 x 6.5
 DIN 6888

Permissible Radial Load F_R
 as Function of the Supporting
 Distance l (for $L_h = 10,000$ h)
 $F_R = f(l)$

Outboard Bearing P, Tapered Shaft End

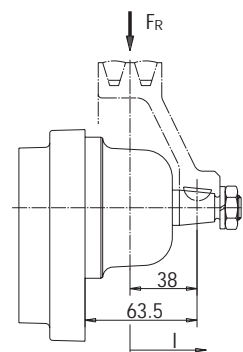
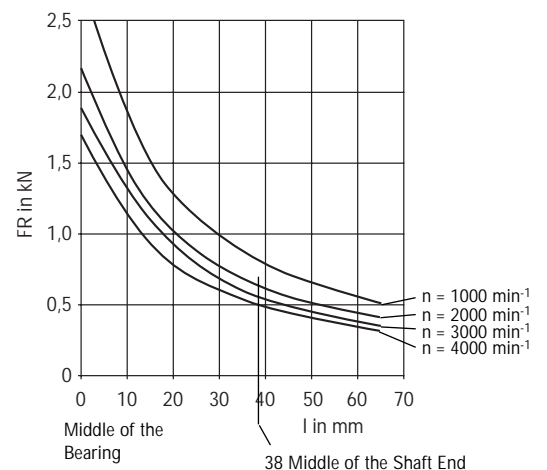
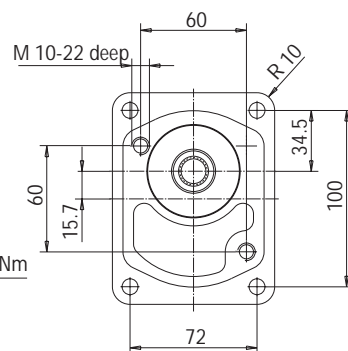
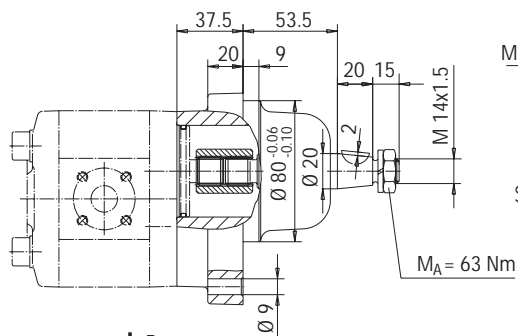

Shaft End: Taper 1:5
 Hex. Lock Nut M 14 x 1.5
 DIN EN 28675
 Curved Spring washer
 B12 DIN 127
 Woodruff key 4 x 6.5
 DIN 6888

Permissible Radial Load F_R
 as Function of the Supporting
 Distance l (for $L_h = 10,000$ h)
 $F_R = f(l)$

Ordering Code: **KM 1/8 Q3PA X0A 4NL1**

Weight of the Outboard Bearing = 3.5 kg

High Pressure Gear Motors KM 1

Mounting Angle, Tapered Shaft End

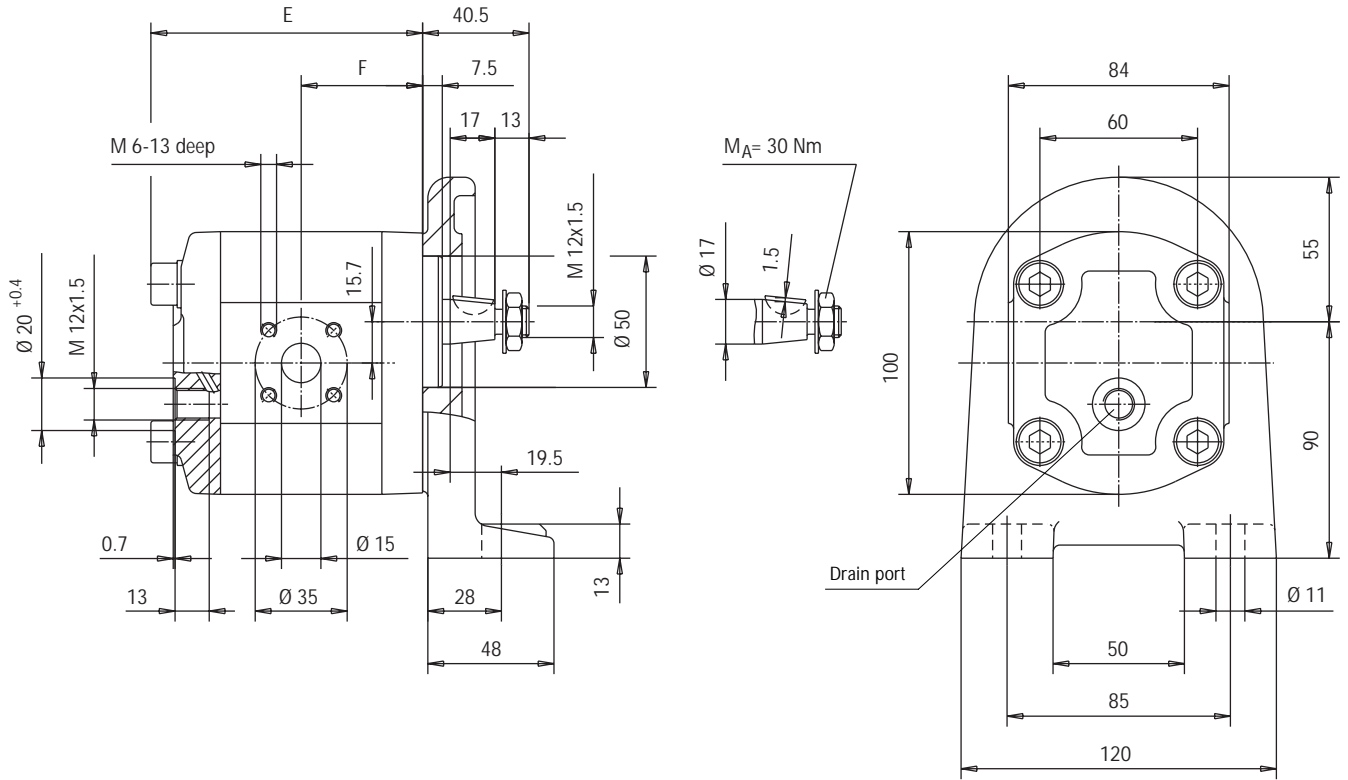

- Shaft End: Taper 1:5
- Hex. Lock Nut M 12 x 1.5
- DIN EN 28675
- Curved Spring washer B12
- DIN 137
- Woodruff key 3 x 6.5
- DIN 6888

Ordering Code:
KM 1/8 F3RA K0A 4NL1

Nominal Displacement	5.5	6.3	8	9.6	11	14	16	19	22
E	89.2	90.6	93.4	96.2	98.4	103.4	106.8	111.8	117.6
F	39.1	39.8	41.2	42.6	43.7	46.2	47.9	50.4	53.3
Weight kg	3.8	3.9	3.9	4.0	4.1	4.2	4.4	4.5	4.7

High Pressure Gear Motors KM 1

Double type, Tapered Shaft End

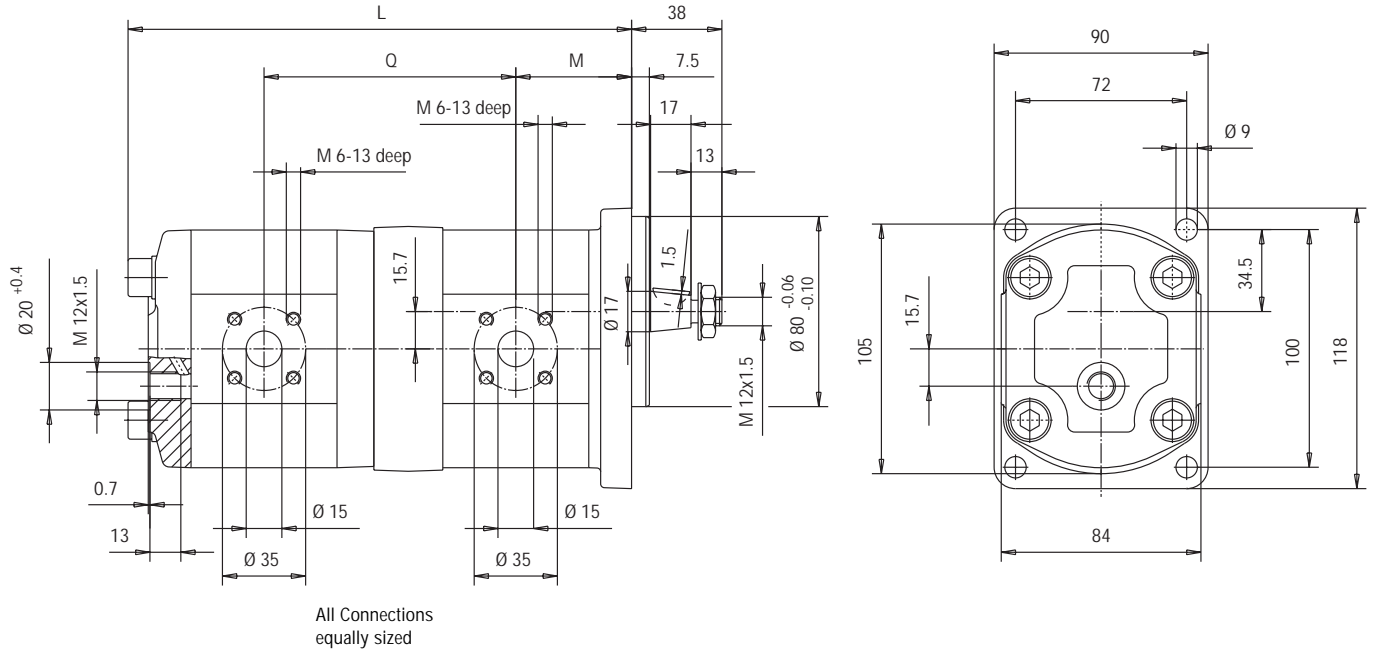

Example

Other flanges and shaft ends possible/available.

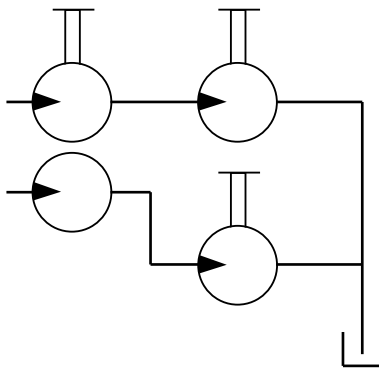

Ordering Code: **KM 1/8 G30A KXF 4NL1/215 + KM 1/8 L30A X0A 4NL1/215**

Nominal Displacement	M	Nominal Displacement	1. Stage																			
			22		19		16		14		11		8		6,3		5,5		4		3	
			Q	L	Q	L	Q	L	Q	L	Q	L	Q	L	Q	L	Q	L	Q	L	Q	L
3	39.5	3	103.8	207.6	100.9	201.8	98.4	196.8	96.7	193.4	94.2	188.4	91.7	183.4	90.3	180.6	89.6	179.2	88.4	176.7	87.5	175.0
4	40.4	4	104.7	209.3	101.7	203.5	99.2	198.5	97.6	195.1	95.0	190.1	92.6	185.1	91.2	182.3	90.5	180.9	89.2	178.5		
5.5	41.6	5.5	105.9	212.1	103.0	206.0	100.5	201.0	98.8	197.6	96.3	192.6	93.8	187.6	92.4	184.8	91.7	183.4				
6.3	42.3	6.3	106.6	213.2	103.7	207.4	101.2	202.4	99.5	199.0	97.0	194.0	94.5	189.0	93.1	186.1						
8	43.7	8	108.0	216.0	105.1	210.2	102.6	205.2	100.9	201.8	98.4	196.8	95.9	191.8								
11	46.2	11	110.5	221.0	107.6	215.2	105.1	210.2	103.4	206.8	100.9	201.8										
14	48.7	14	113.0	226.0	110.1	220.2	107.6	215.2	105.9	211.8												
16	50.4	16	114.7	229.4	111.8	223.6	109.3	218.6														
19	52.9	19	117.2	234.4	114.3	228.6																
22	55.8	22	120.1	240.2																		

High Pressure Gear Motors KM 1

Flow-divider KM 1

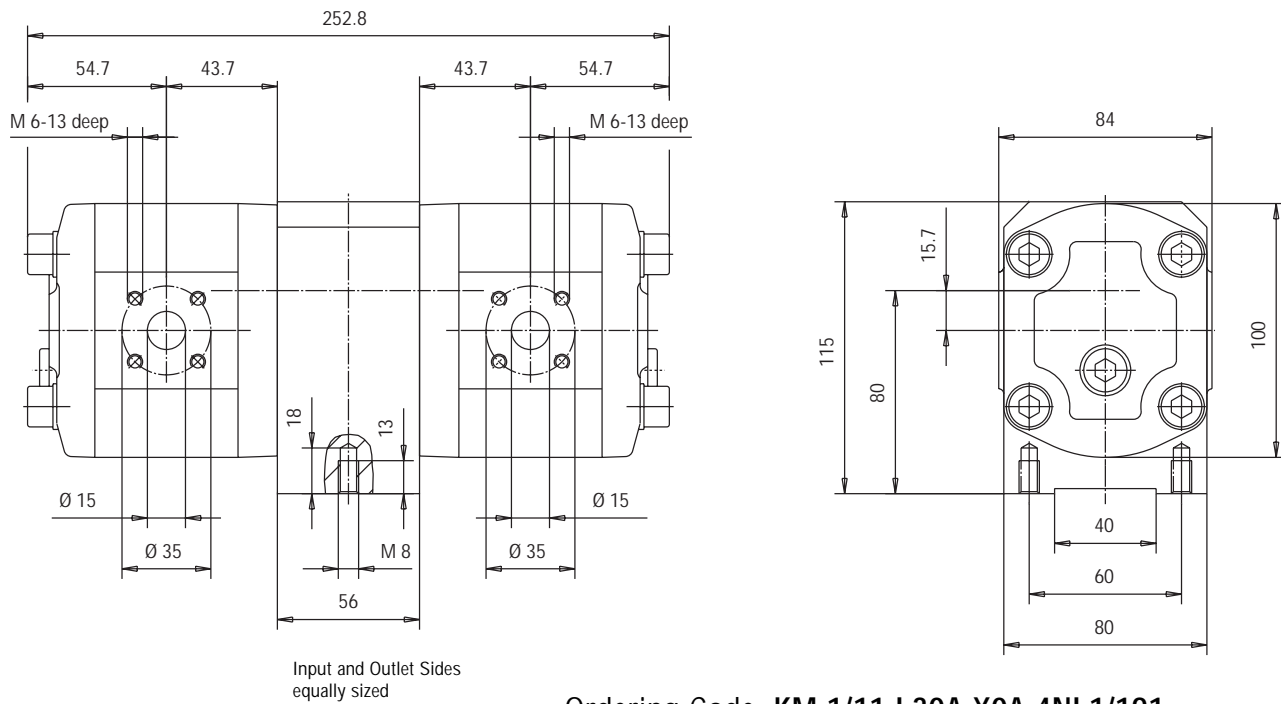
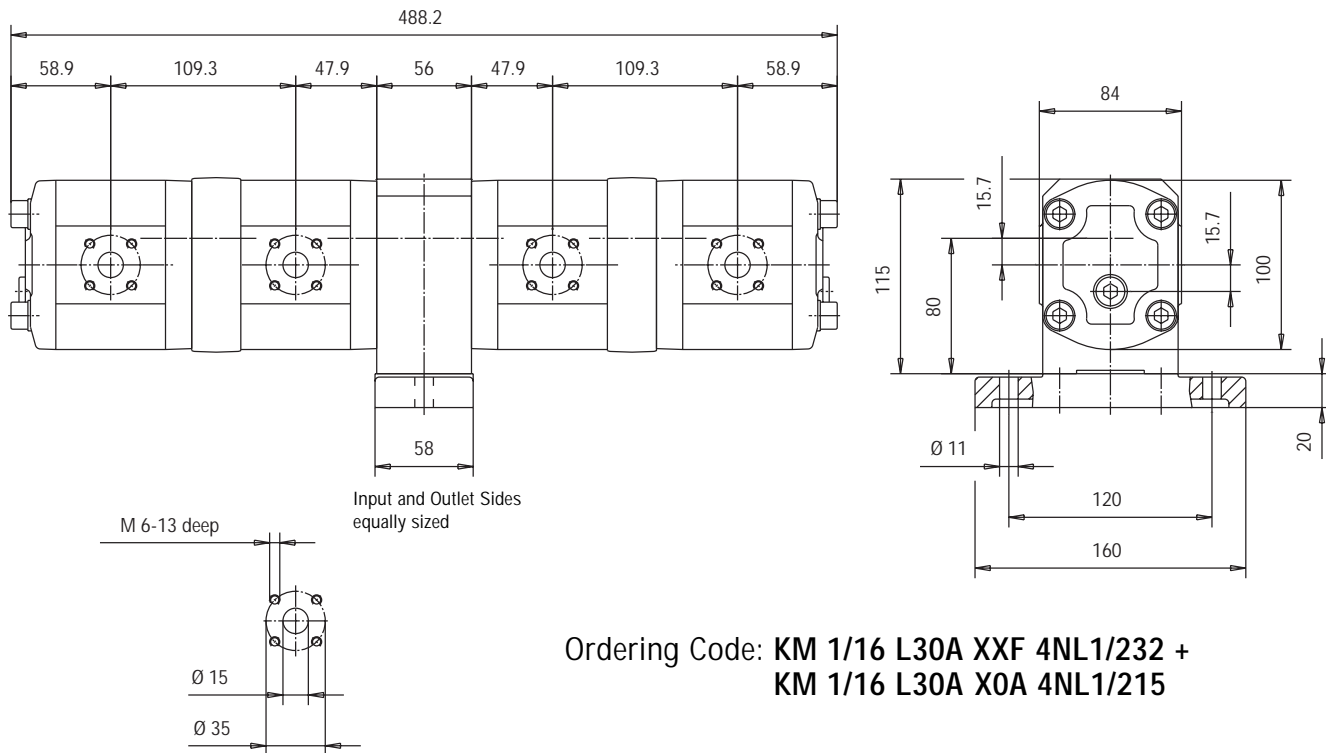

High Pressure Gear Motors KM 1

Coupling and Accessories

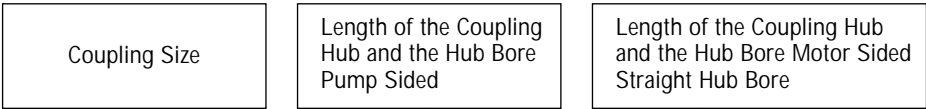
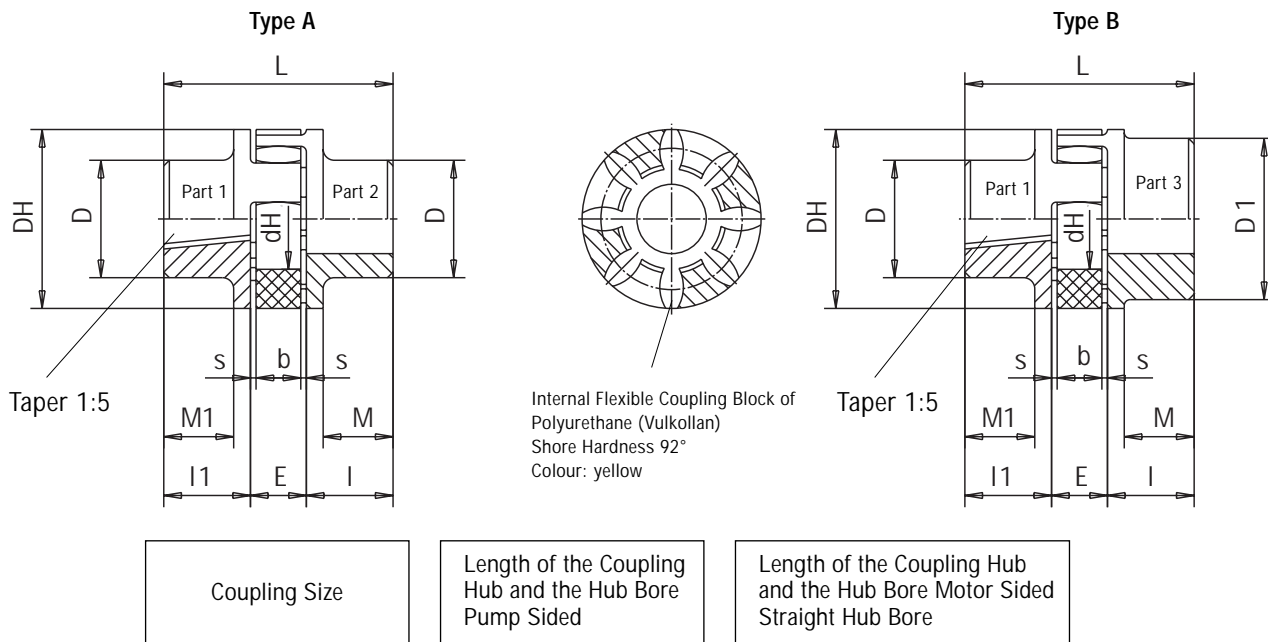

Ordering Code:

RA 38 - K 18/17 - Z 45/38

	Coupling Size	Weight kg	Moment of Inertia kgm ²	Rough Bore		Finished Bore				Dimensions								Ordering Code				
				Part 2	Part 3	min. Part 2	min. Part 3	max. Part 2	max. Part 3	I	I ₁	E	s	b	L	M	M ₁		D _H	D	D ₁	d _H
Type A	24	0.2	0.00008	-	-	9	-	24	-	30	18.5	18	2	14	66.5	24	12.5	55	40	-	27	RA 24-K18/17-Z 30/...
	28	0.35	0.0002	-	-	10	-	28	-	35	18.5	20	2.5	15	73.5	28	11.5	65	48	-	30	RA 28-K18/17-Z 35/...
	38	0.75	0.0007	-	-	12	-	38	-	45	18.5	24	3	18	87.5	37	10.5	80	66	-	38	RA 38-K18/17-Z 45/...
	42	1.15	0.0014	25	-	28	-	42	-	50	18.5	26	3	20	94.5	40	8.5	95	75	-	46	RA 42-K18/17-Z 50/...
Type B	24/28	0.22	0.0001	-	20	-	22	-	28	30	18.5	18	2	14	66.5	24	12.5	55	40	56	27	RA 24/38-K18/17-Z 30/...
	28/38	0.42	0.0003	-	23	-	28	-	38	35	18.5	20	2.5	15	73.5	28	11.5	65	48	67	30	RA 28/38-K18/17-Z 35/...
	38/45	0.82	0.0008	-	36	-	38	-	45	45	18.5	24	3	18	87.5	37	10.5	80	66	77	38	RA 38/45-K18/17-Z 45/...
	38/45	2.5	0.0020	-	-	-	38	-	45	70	18.5	24	3	18	112.5	62	10.5	80	66	78	38	RA 38/45-K18/17-Z 70/...
	42/55	1.29	0.0018	-	25	-	42	-	55	50	18.5	26	3	20	94.5	40	8.5	95	75	94	46	RA 42/55-K18/17-Z 50/...

Operating Temperature: - 40 °C bis + 90 °C (Short Time Temperature peaks up to + 120 °C are permissible)

RA: Hub Material Al

Weights as well as Moments of Inertia relate to the max. bore dia. after final machining – but without key-way.

RG: Hub Material Part 2 and 3 GG

Bore Finish acc. to ISO-Fit Class H7; Key-Ways acc. to DIN 6885 / Part 1.

Coupling Sleeve:

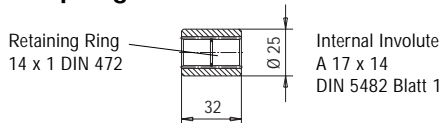

Coupling Sleeve Size 1
Partnumber: B.0079020001

Coupling KP1 K-Shaft
Partnumber : E.0187220001

Coupling:

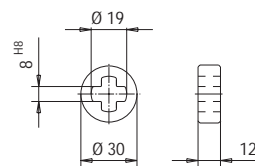

Coupling KP 1L
Partnumber : E.0104040001

High Pressure Gear Motors KM 1

Straight Flanged Connector

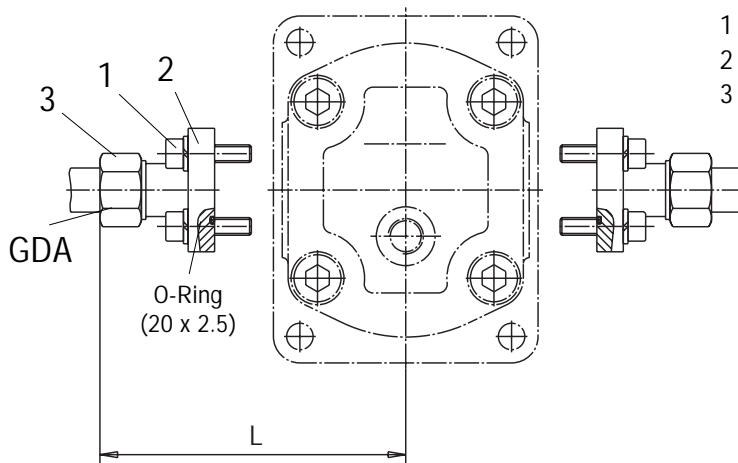

- 1 Hex. Socket Head Cap Screw (DIN 912 – 8.8)
- 2 Single Coil Spring Lock Washer (A6 DIN 127)
- 3 Covering Nut with Cutting Ring (SW)

Inlet Port Pipe Externa Dia. mm	Ordering Code	Rated Pressure P_N in bar	Dimensions		Cap Screw	Weight kg
			L	SW		
16	GDA 1/16	315	82	30	4 x M6 x 22	0.18
15	GDA 1/15	250	81	27	4 x M6 x 22	0.17
12	GDA 1/12	315	81	22	4 x M6 x 22	0.16

Elbow Flanged Connector

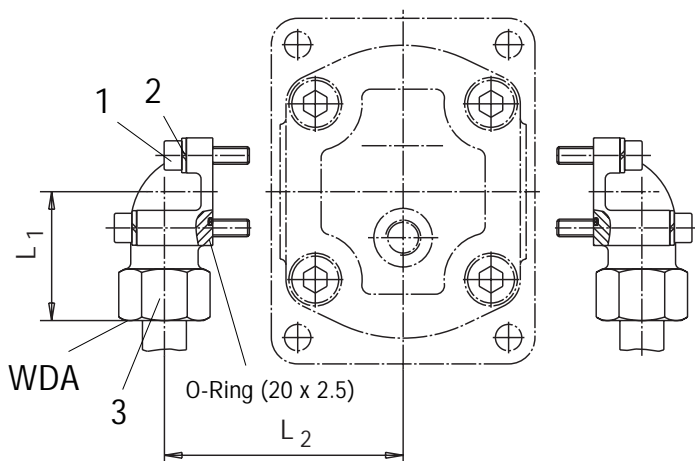

Ordering Code of a complete connection:
 For the Inlet Port:
 Straight Flanged Connector **GSA 1/22**
 For the Outlet Port:
 Elbow Flanged Connector **WDA 1/20**

Extend of Kracht Delivery: Hex. Socket Head
 Cap Screw acc. to DIN 912 as well as Single
 Coil Spring Lock Washers and O-Rings.

Inlet Port Pipe Externa Dia. mm	Ordering Code	Rated Pressure P_N in bar	Dimensions			Cap Screw	Weight kg
			L ₁	L ₂	SW		
20	WDA 1/20	315	56	67	36	2 x M6 x 45 2 x M6 x 22	0,40
16	WDA 1/16	315	48	62	30	2 x M6 x 40 2 x M6 x 22	0,28
15	WDA 1/15	250	46	58,5	27	2 x M6 x 35 2 x M6 x 22	0,22
12	WDA 1/12	315	47	58,5	22	2 x M6 x 35 2 x M6 x 22	0,20

Overview of our complete programme

Transfer pumps

Transfer pumps for lubricating oil supply equipment, low pressure filling and feed systems, dosing and mixing systems, including PUR.

Volutronic®

Gear flow meters and electronics for volume and flow metering technology in hydraulics, processing and laquering technology.

Mobile hydraulics

Single and multistage high pressure gear pumps, hydraulic motors and valves for construction machinery, vehicle-mounted machines.

Industrial hydraulics

Cetop directional control and proportional valves, hydraulic cylinders, pressure, quantity and stop valves for pipe and slab construction, hydraulic accessories for industrial hydraulics (mobile and stationary use).

With our decades of experience, we are at your side, world-wide, for the professional mastery of specific applications and complete solutions in hydraulics and process technology.



KM1.e.12.2000